

MicroTron

Series G

Chemical Metering Pump

***Digitally
Accurate
Speed
Adjustment***

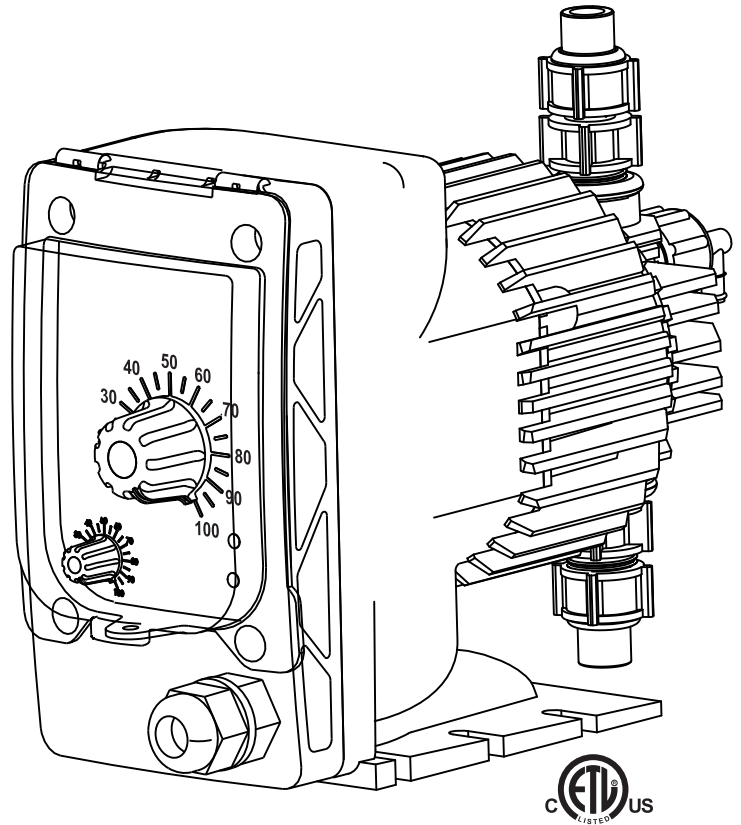

Key Features

- Dual Output Adjustment
- NEMA 4X Style Enclosure
- Guided Double Ball Checks
- Circuit Voltage Protection
- Thermal Overload Protection
- Priming / Degassing Valve
- LED Indicating Lights
- Splash Cover Over Controls
- 2 Year Warranty

Application

MicroTron Series G metering pumps provide reliable, economical chemical addition for a wide variety of applications.

Precise stroking speed is maintained with a digitally accurate speed adjustment. Metering accuracy is achieved with double ball guided checks. A NEMA 4X style housing allows for outdoor installations.

Series G pumps are available in outputs up to 45 GPD and 250 PSI. The manual stroke length and digital speed adjustment provides a wide turn down capability on all models.

Build a Model

Model G _____ - _____

Build your model number by selecting one code from each step. Example: G130X1-KVC1

STEP 1 OUTPUT (MAXIMUM)

- 115 = 15 GPD / 2.37 LPH at 150 PSI (10.3 bar)
- 130 = 30 GPD / 4.70 LPH at 110 PSI (7.5 bar)
- 145 = 45 GPD / 7.09 LPH at 75 PSI (5.1 bar)
- 217 = 17 GPD / 2.60 LPH at 250 PSI (17.2 bar)

STEP 2 CONTROL OPTIONS

- X = Standard
- D = Dual Output 10-50 sph or 1-125 spm
- E = External Pace
- L = Limit Timer

STEP 3 VOLTAGE

- 1 = 120 Volt USA Plug
- 2 = 240 Volt
- 3 = 240 Volt Specified Plug
- 4 = 12 Volt Operation
- 7 = 240V with Australia plug

STEP 4 HEAD MATERIAL

- K = Kynar
- S = Stainless

STEP 5 SEAT MATERIAL

- V = Viton
- F = Teflon
- H = Hypalon

STEP 6 CHECK BALL

- C = Ceramic
- S = Stainless

STEP 7 CONNECTIONS

- 1 = 3/8" (9.525 mm) Tubing - 110 & 150 PSI
- 2 = 1/4" (6.35 mm) Tubing - 250 PSI
- Q = Stroke length adjustment

For other options, see Price List or consult factory.

Accessories

Standard models include everything needed for immediate start-up: injection, foot and priming valve assemblies plus suction and discharge tubing.

Specifications

Electrical

- Input - 120 VAC or 240 VAC @ 50/60 Hz

Operational

- Stroke length adjustment - 10-100%
- Stroke frequency - 1-125 strokes/minute for 15, 30 & 17 GPD; 1 - 145 strokes / min. for the 45 GPD

Enclosure

Heavy duty NEMA 4X style high impact thermoplastic with clear lexan cover.

Environment

- Ambient temperature 32° to 140°F (0 to 60°C)
- Relative humidity 0 to 100%

Shipping Weight: Approximately 10 lbs. (4.536 kg)

