

## Installation, Operation and Maintenance Manual



## Pre-Engineered Skid Systems

## **Pulsafeeder Factory Service Policy**

Should you experience a problem with your Pre-Engineered Skid System, first consult the troubleshooting guide in this operation and maintenance manual, as well as the information in the manual for your Pulsatron pump. If the problem is not covered or cannot be solved, please contact your local Pulsafeeder Sales Representative or Distributor, or our Technical Services Department for further assistance.

Trained technicians are available to diagnose your problem and arrange a solution. Solutions may include purchase of replacement parts or returning the unit to the factory for inspection and repair. All returns require a Return Authorization number to be issued by Pulsafeeder. Parts purchased to correct a warranty issue may be credited after an examination of original parts by Pulsafeeder. Warranty parts returned as defective which test good will be sent back freight collect. No credit will be issued on any replacement electronic parts.

Any modifications or out-of-warranty repairs will be subject to bench fees and costs associated with replacement parts.

**Copyright ©2011 Pulsafeeder, Inc. All rights reserved.**

Information in this document is subject to change without notice. No part of this publication may be reproduced, stored in a retrieval system or transmitted in any form or any means electronic or mechanical, including photocopying and recording for any purpose other than the purchaser's personal use without the written permission of Pulsafeeder, Inc.

## Table of Contents

<u>Topic</u>	<u>Page</u>
Introduction.....	4
Safety .....	5
Skid Layout and Component Descriptions .....	6
Systems Overview .....	7
Supply Side .....	7
Process Side .....	8
Installation .....	10
Owner Installed Piping/Tubing.....	11
Pump Priming .....	12
Flooded Suction .....	12
Suction Lift .....	13
System Components and Settings.....	14
Pressure Relief Valve .....	15
Back Pressure Valve .....	15
Pulsation Dampener, Setting .....	16
Setting Pressure Relief Valve .....	17
Setting Back Pressure Valve.....	17
Flow Calibration .....	18
Routine Maintenance .....	21
Troubleshooting.....	22
Appendix, Table 1 .....	23

## Introduction

Congratulations! With the Pulsafeeder Pre-Engineered Skid System, you have the finest chemical dosing equipment platform available. This system includes the essential elements for successful installation and operation of your dosing pump(s). You are encouraged to:

### **READ THIS MANUAL!**

Pulsafeeder Pre-Engineered Skid Systems are designed to support single and dual pump installations. The skid components (valves, gauges, interconnecting piping, etc.) are furnished to meet your specified operational requirements. The Dosing Pump(s), per se, may be furnished separately, so installation, operation and maintenance instructions for pump(s) are located elsewhere. A listing of Pulsafeeder Pulsatron Electronic Metering Pumps that are typically used with these systems is located in the Appendix for this manual.



### **Single Pump System**

For applications handling one dosing chemical

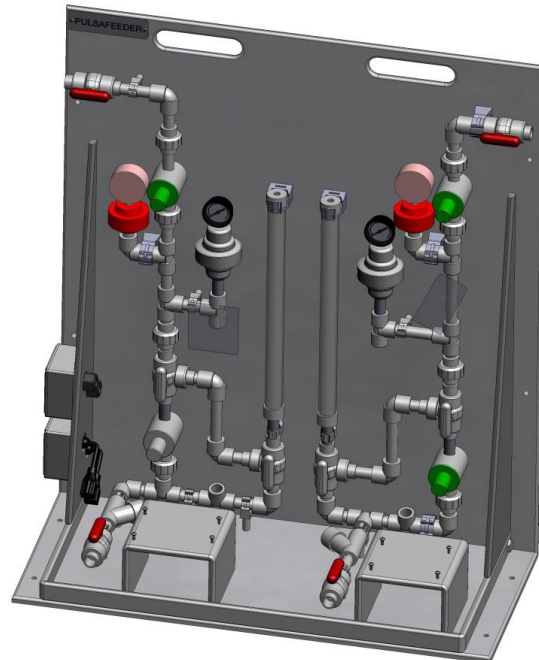

### **Dual Pump System**

Can be used for:

- Two different chemicals
- One chemical, alternating pump operation
- One chemical, two-pump operation

*Figure 1  
Skid System Arrangements*

---

## Installation, Operation and Maintenance Manual

---

### Safety

Your safety is of the utmost concern to Pulsafeeder. Dosing pumps and systems can handle harsh or toxic chemicals and exposure can lead to serious injury or death. Always wear appropriate protective clothing (for example, safety glasses, gloves, coveralls, etc.) and follow safe handling procedures. Pay attention to what you're doing and note safety advisories where they are shown throughout this manual. Some examples of safety issues and precautions for Pulsafeeder Pre-Engineered Skid Systems are:

**WARNING**

**Do NOT** use Pulsafeeder Skid Systems (or Pulsafeeder Pumps) for flammable liquids.

**WARNING**

Prior to working on any portion of the Skid System, disconnect pump(s) from power supply, de-pressurize the system and drain chemicals from the lines.

**WARNING**

Inspect tubing regularly and replace as necessary.  
**When inspecting tubing, wear protective clothing and safety glasses.**

**CAUTION**

If skid is exposed to sunlight, use UV-resistant tubing.

**CAUTION**

Follow directions and warnings provided with chemicals from the chemical manufacturer. User/owner is responsible for determining chemical compatibility with chemical feed pump(s) and system components.

**CAUTION**

Secure chemicals, metering pump(s) and system, making them inaccessible to children, pets and unauthorized personnel.

**WARNING**

**Always wear protective clothing** including gloves and safety goggles when working on or near chemical metering pumps and systems.

**CAUTION**

Installation and start-up of chemical dosing system will require both mechanical (plumbing) and electrical work. Only qualified and licensed plumbers and electricians should perform this.

Installation, Operation and Maintenance Manual

**Skid Layout and Components**

Figure 2, below, illustrates a dual pump skid system (Pulsafeeder Designation “2A”) for flooded suction (chemical source above the pump centerline) as shown on Page 7. This system can be used for two different chemicals or for redundant pump operation with one chemical. Your skid system may be less complex than this. Note the various components and their descriptions as they apply to your skid system.

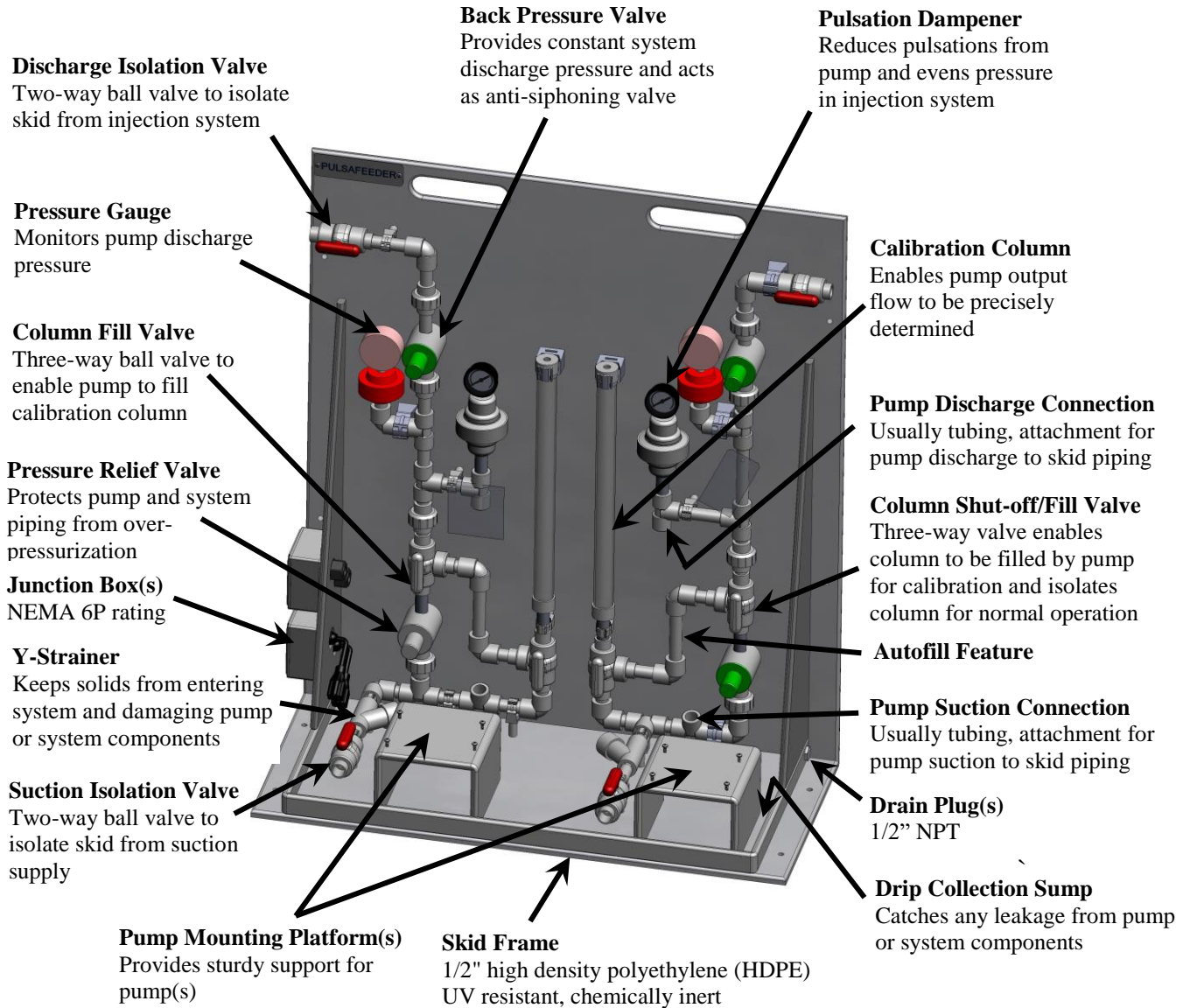
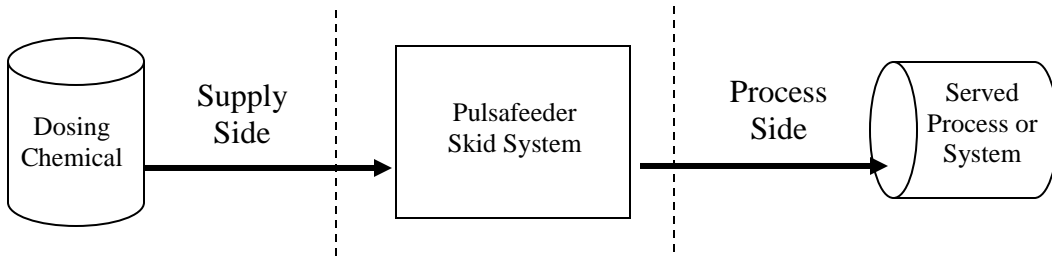

*Figure 2  
Skid Layout and Components*

Installation, Operation and Maintenance Manual

**Systems Overview**

The Pulsafeeder Pre-Engineered Skid System is designed to pump chemicals at precisely controlled rates into another process or system.



Proper arrangement of piping and appurtenances on both the supply side and the process side are critical to the successful operation of the overall system. These are the responsibility of the owner/operator of the system, and attention should be paid to the comments, below:

**Supply Side**

Dosing chemicals are usually sourced from a barrel or tote container. The source may be located above the centerline of the pump(s) which is referred to as a “flooded suction” or it may be located slightly below the centerline of the pump(s) which is referred to as “suction lift.” Connections to and from the Solution Tank are most commonly made with flexible hose or tubing although they may be made with hard piping. Solution Tank should be covered to prevent contamination.

**Flooded Suction**

*This is the most trouble free type of installation. Since the Supply Line tubing is filled with chemical, priming is accomplished quickly and the chance of losing prime is reduced.*

*Recommended for very low flow rate applications. e.g. 2 ml/hr, or where pumping solutions such as sodium hypochlorite or hydrogen peroxide which can form air bubbles.*

*Supply Line should gradually slope downward from the Solution Tank to the Skid Suction Connection.*

*It is strongly recommended to add a drain provision on the suction side to facilitate emptying and flushing of the system for maintenance.*

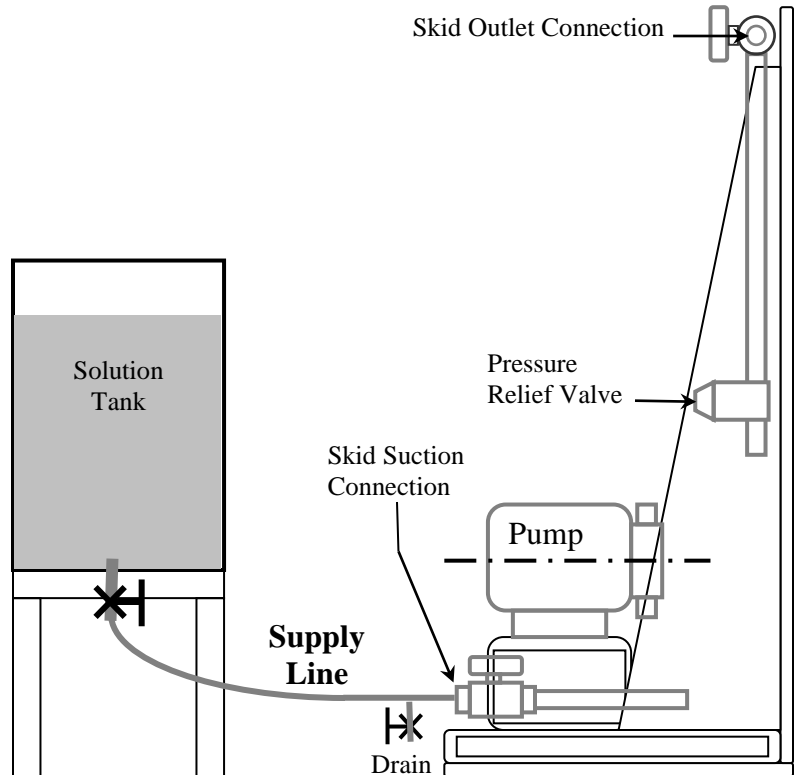

Figure 3  
Flooded Suction

Installation, Operation and Maintenance Manual

**Supply Side, Continued**

**Suction Lift**

*This is the most common arrangement for chemical metering applications since there is less chance of spillage.*

*Note that the maximum recommended lift is 5 feet (1.5m).*

*Since the Supply Line will be in a vacuum condition, attention should be paid to the vapor pressure of the pumped liquid. Vapor formation in the Supply Line will prevent the pump from pumping.*

*Supply Line should gradually slope up to the Skid Suction Connection to prevent air pocket(s) which can impede flow.*

*It is strongly recommended to add a drain provision on the suction side to facilitate emptying and flushing of the system for maintenance.*

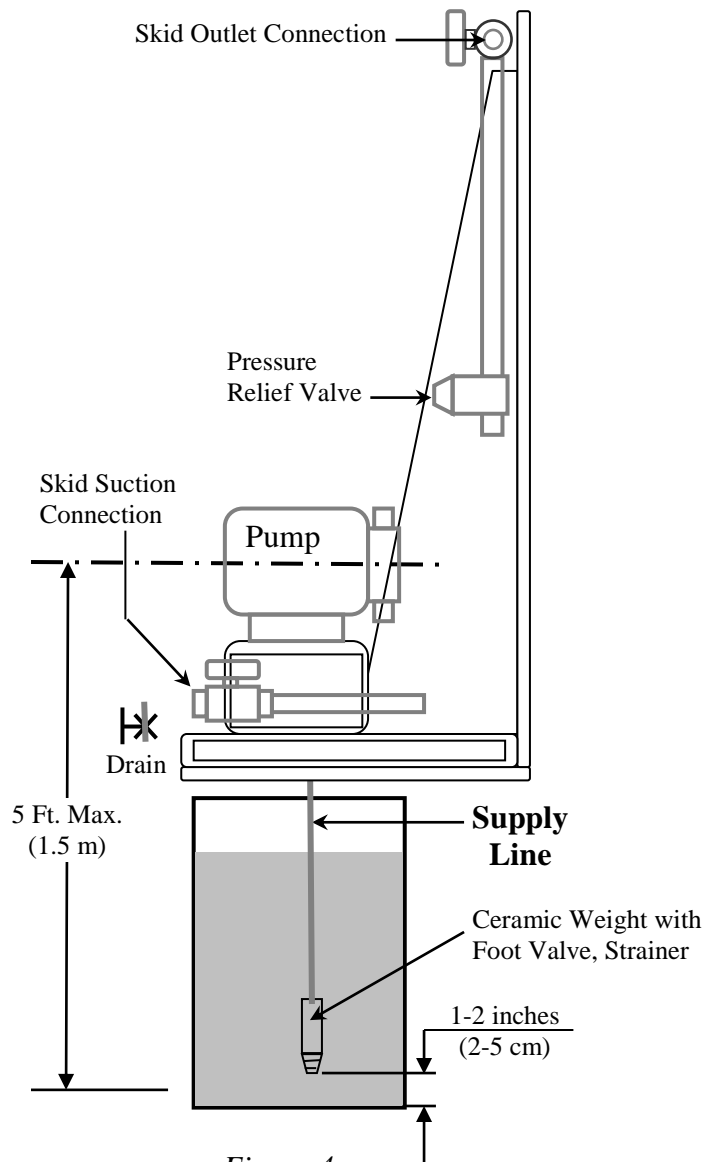

Figure 4  
Suction Lift

**Process Side**

The injection point in the served process or system **must** be higher than the top of the Solution Supply Tank to prohibit gravity feeding unless suitable backpressure is always present at the injection point. In applications where the injection point is below the Solution Supply Tank (example – injection into a well) or where the injection point may be at reduced pressure (example – injection into the suction side of a pump), installation of an anti-siphon valve in the process feed line will prevent gravity feeding.

Note: For dosing chemicals that create gas in the suction line consider a Flooded Suction supply configuration.

Continued.....



Installation, Operation and Maintenance Manual

**Process Side, Continued...**

Note comments on Process Side Piping/Tubing on the illustration, below:

**Pressure Dissipation, Drain, Vent, Flush Provision**  
It is strongly recommended that this type of provision be added to the process side of the injection system to facilitate maintenance.



When system pressure is dissipated or when venting, spray may occur which could cause serious harm or injury. **Include provisions to contain any possible spray as well as being able to drain safely.**

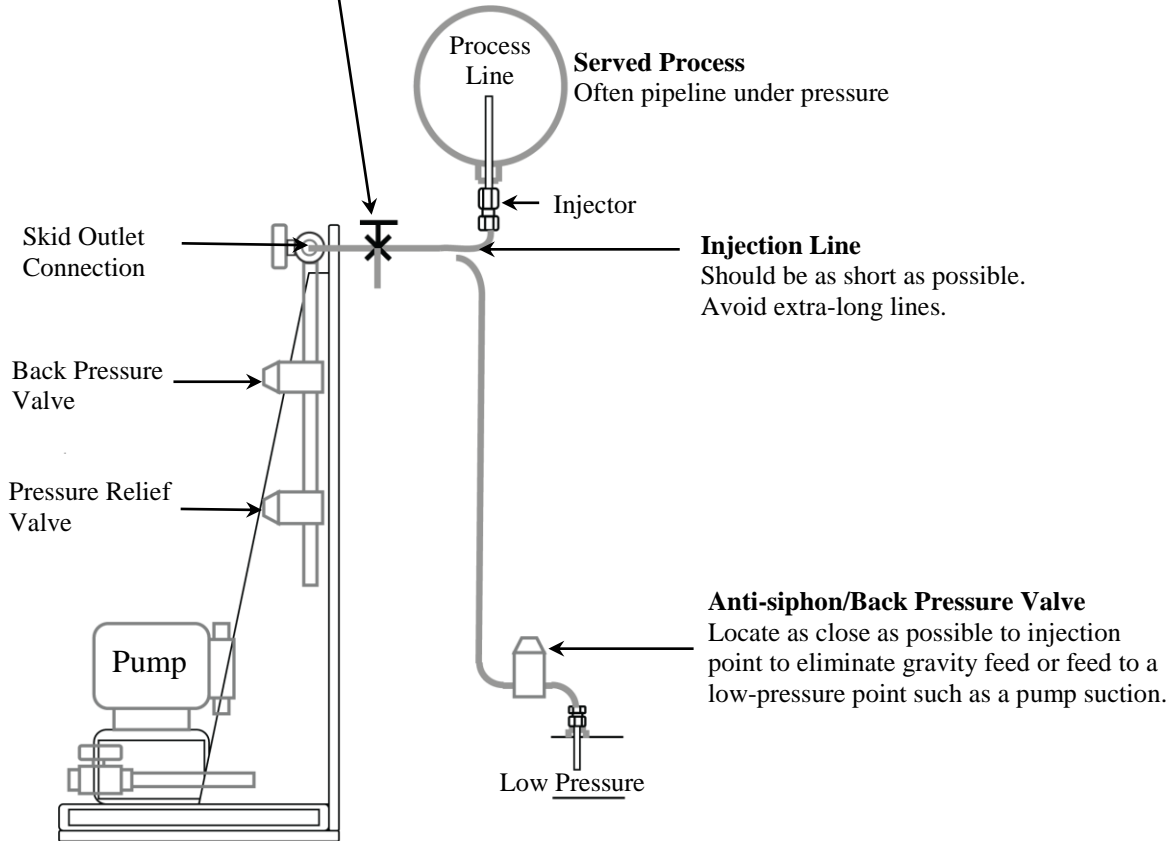

*Figure 5  
Process Piping Considerations*

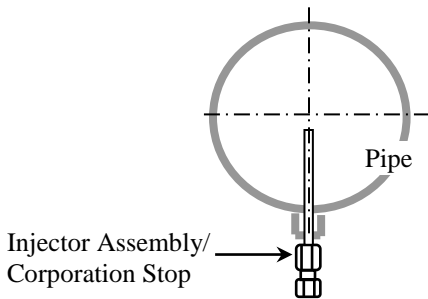

**Injection Point**  
Injected chemicals may be corrosive to piping. To minimize corrosive effects, locate injector tip near center of process flow where velocities and mixing are at their highest rate. Trim tip as necessary. For larger pipe installations, longer injection assemblies are available.

*Figure 6  
Injection Point*

## Installation, Operation and Maintenance Manual

### Installation

Prior to attempting installation, familiarize yourself with the layout and components furnished with your Pulsafeeder Pre-Engineered Skid System. These vary from system to system – review the documentation supplied with your order. Inspect your skid system for damage which may have occurred during transit. If damage is discovered, immediately file a claim with the carrier and contact your Pulsafeeder distributor for any required replacement parts or components.

**Skid systems (and pumps) have been tested with water at the factory.**



**CAUTION**

Some dosing chemicals will react with water, e.g., acids, polymers, etc. Check MSDS for the chemical to be handled. If adverse reaction with water is indicated, ensure that all portions of the skid piping, its components (and the pump) are free from water prior to filling skid system with chemical.

Skid systems may be wall- or floor-mounted. Mounting holes are provided on the skid for both types of mounting. Securely attach skid in its installation position to prevent falling or tipping.

Installation area should provide ease of access to skid components (and pumps) and the area should be kept free of clutter to enable safe operation and maintenance.

Note that pumps/motors are designed for ambient temperatures of 104°F (40°C) **maximum**. It is preferable that skid systems (and pumps) be located out of direct sunlight. If skid system is exposed to sunlight, provide protection for the pump/motor to prevent overheating and failure to operate.



**CAUTION**

If skid is exposed to sunlight, use UV-resistant tubing.

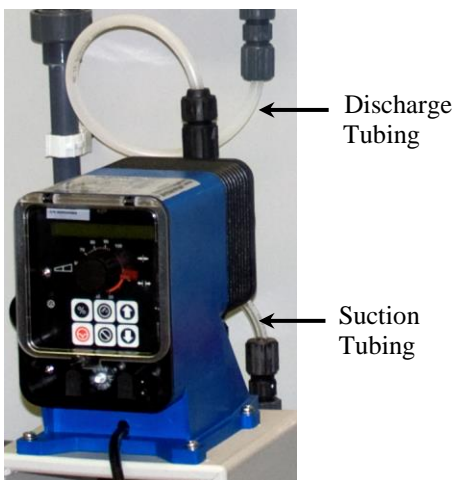

*Figure 7  
Pump-to-Skid Tubing Connections*

Most Pulsafeeder Pre-Engineered Skids will have Pulsatron pump(s) mounted on them at the factory, and the pump(s) will be connected to the piping integral to the skid with tubing.

If larger size Pulsatron pumps are to be used, the pumps are normally shipped separately. If this is the case, or if another pump is to be used with the skid, once the skid system is securely in place, install the pump(s) on the pump mounting platform(s). These should be bolted in place, firmly fastened.

Connect the pump suction and discharge to the corresponding piping connections on the skid-mounted piping. See Page 6 for location(s) of these piping connections. This is usually done with tubing, however always ensure that the connection material is compatible with the chemical to be pumped and suitable for the pressures and temperatures. Tubing connection fittings are usually plastic in which case they should be hand-tight only.

Installation, Operation and Maintenance Manual

---

**Installation, Continued...****Owner-Installed Piping/Tubing**

The next series of steps are the connection of your piping/tubing which include the chemical supply line, discharge line, pressure relief/bypass line and an air bleed return line.

These are your responsibility and



Ensure that for all piping, tubing, fittings and other appurtenances, their materials are compatible with the liquid to be pumped and the design is suitable for the pressures and temperatures of the application. System design must ensure safety for operation and maintenance as well as for anyone who may be in proximity to the system. Failure to do so may result in damage to equipment, personal injury or death.

**Suction Line**

This line connects the source of the dosing chemical to the Pulsafeeder Pre-Engineered Skid. Please refer to Figure 3 and Figure 4 on Pages 7 and 8 respectively. If the source is below the centerline of the pump (suction lift condition), ensure that the suction line has a gradual rise up to the skid suction connection. If the source is above the centerline of the pump, ensure that the suction line has a gradual slope down to the skid suction connection. The purpose of this is to prevent air pocket(s) in the suction line which could affect proper operation of the pump. Include whatever provisions you consider necessary to facilitate maintenance and operation such as isolation valve(s), drain and/or flush connections, etc., making sure that this sub-system enables **SAFE OPERATION**.

**Discharge Line**

This line connects the Pulsafeeder Pre-Engineered Skid to your served process. Please refer to the general description on Pages 8 and 9 and Figure 5 and Figure 6. This line should include the injector assembly that is usually furnished with the pump. If the injection point is below the dosing chemical source or if injecting into a low pressure area such as the suction of a pump, an anti-siphon/ back pressure valve should be located as close as possible to the injection point to prevent unwanted chemical feeding. Include whatever provisions you consider necessary to facilitate maintenance and operation such as isolation valve(s), drain and/or flush connections, etc., making sure that this sub-system enables **SAFE OPERATION**.

## Installation, Continued...

### Owner-Installed Piping/Tubing, Continued...

#### Air Bleed Valve Bypass Line

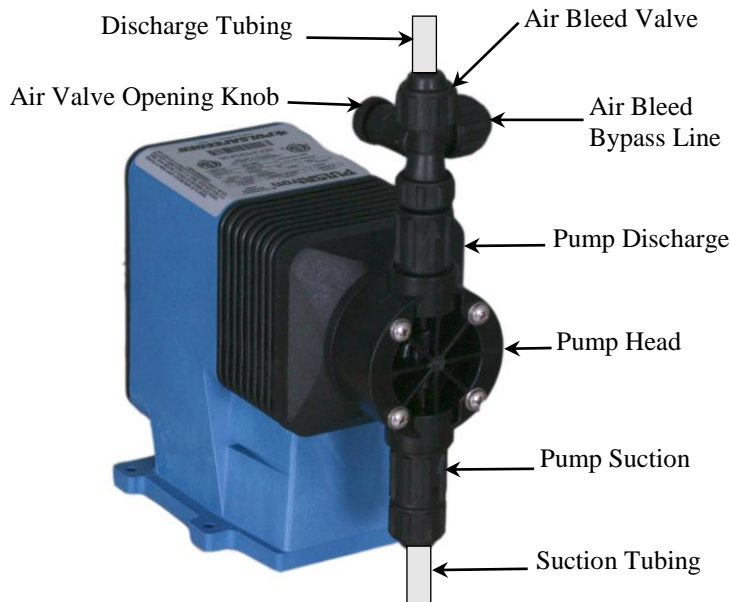

*Figure 9  
Air Bleed Valve Configuration*

Although most metering pumps are self-priming, they can not pump against pressure when handling air in the priming cycle. An air bleed is necessary to enable the pump to prime, and an air bleed valve is provided for this. During the priming process, the air bleed valve is opened with the opening knob. Air will pass through the Air Bleed Bypass Line until the pump body is filled with process fluid. When the process fluid flows through the Bypass Line without any air bubbles, the pump is primed. The opening knob is then closed, and the pump is ready for operation. Connect the Air Bleed Bypass Line to a suitable receptacle. This is often the suction source but can be a separate container. Firmly fix the outlet of the Air Bleed Bypass Line within the receiving receptacle to prevent any possible spraying.

Check all piping and tubing connections on the skid to ensure they are tight.

Check all other system piping and/or tubing connections to ensure they are tight.

Installation, Operation and Maintenance Manual

**Initial Prime**

The pump must be primed before it can function within the system. This will require an initial start of the pump.



Thoroughly review the installation, operation and maintenance manual for your pump prior to starting. Follow pump startup instructions. Failure to do so may result in damage to equipment or serious injury.

**Flooded Suction System**

1. Close Skid Discharge Valve and Column Isolation Valve
2. Open Air Bleed Valve (turn opening knob counterclockwise, see Figure 9)
3. Open all valve(s) on the suction side – Skid Suction Connection Valve and any valve(s) in your suction line
4. Connect pump/motor to power source (pump/motor off)
5. Start pump using manufacturer’s recommendations for initial operation settings
6. Observe flow through Air Bleed Bypass. When solid stream (no air bubbles) is observed, pump is primed.
7. Close Air Bleed Valve (turn opening knob clockwise)

Note:

Pulsafeeder Pulsatron metering pumps, most commonly used on Pulsafeeder Pre-engineered Skid Systems, are self-priming.

If you are not using a Pulsatron pump, check the specifications for your pump to ensure priming capability or provision for priming.

When starting an empty pump, use of the air bleed valve is recommended. In any case, provision must be made to evacuate air from the pump discharge port during priming.

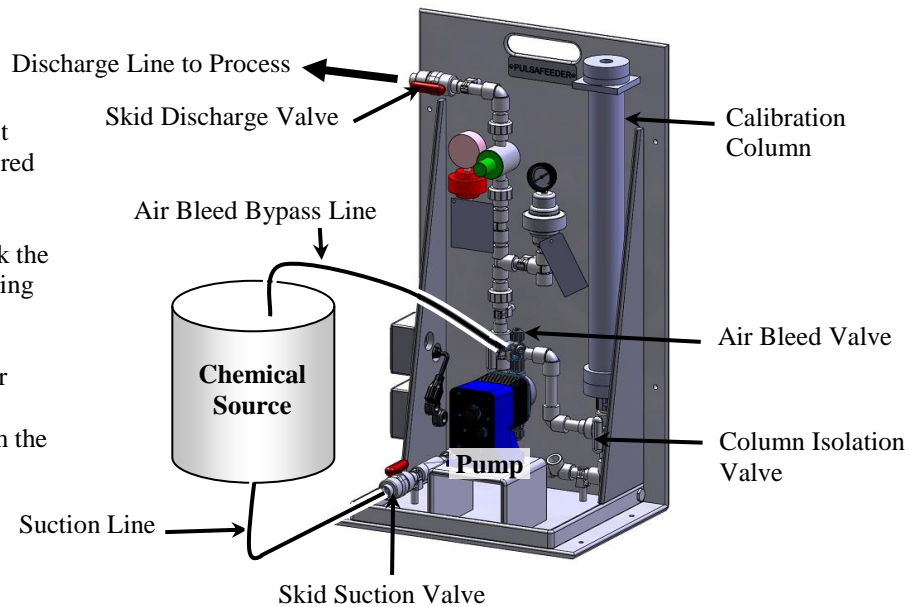

*Figure 10  
Pump and Suction System Setup for Prime  
Flooded Suction*

**Initial Prime, Continued...**

**System with Suction Lift**

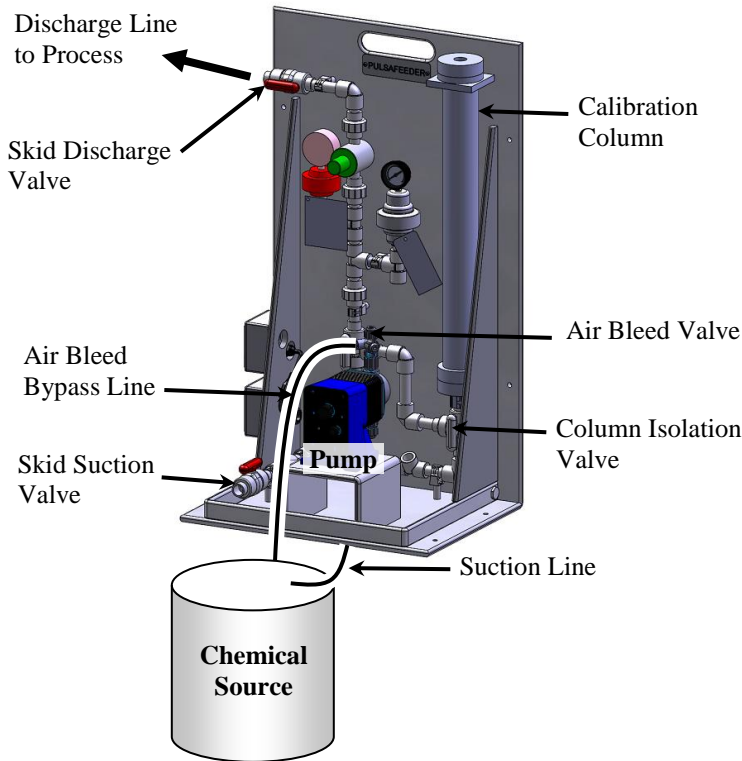

With a suction lift configuration, the entire suction arrangement (suction line and Skid suction piping) as well as the pump must be purged of air before the pump can function. The pump can evacuate the air, however this may take considerable time.

Optional:

**If the dosing chemical can be handled safely**, it may be helpful to add dosing chemical to the suction assembly via the top of the calibration column. This requires the installation of a foot valve at the entrance to the suction line within the chemical source container. Open the Air Bleed Valve turning the opening knob counterclockwise (see Figure 9). Open - Column Isolation Valve. Open all valves in the Suction Line. Add dosing chemical into the top of the Calibration Column until liquid remains visible. Follow steps, below. Note that Air Bleed Valve is open.

*Figure 11*

*Pump and Suction System Setup for Prime Suction Lift Configuration*

1. Close Skid Discharge Valve and Column Isolation Valve
2. Open Air Bleed Valve (turn opening knob counterclockwise, see Figure 9)
3. Open all valve(s) on the suction side – Skid Suction Connection Valve and any valve(s) in your suction line
4. Connect pump/motor to power source (pump/motor off)
5. Start pump using manufacturer’s recommendations for initial operation settings
6. Observe flow through Air Bleed Bypass. When solid stream (no air bubbles) is observed, pump is primed.
7. Close Air Bleed Valve (turn opening knob clockwise)

## Installation, Operation and Maintenance Manual

## Setting Valves and Pulsation Dampener

If furnished with your Pulsafeeder Pre-Engineered Skid System, the Pressure Relief Valve, Back Pressure Valve and Pulsation Dampener will be pre-set at the factory in accordance with Table 1 located in the Appendix of this manual. These pressure settings are related to the piping and components furnished with your skid as well as the pump(s) if furnished with the skid. Your system requirements may require changes to these settings, and the valves will have to be re-set after maintenance such as diaphragm replacement. A general description and the setting procedures for these components are as follows:

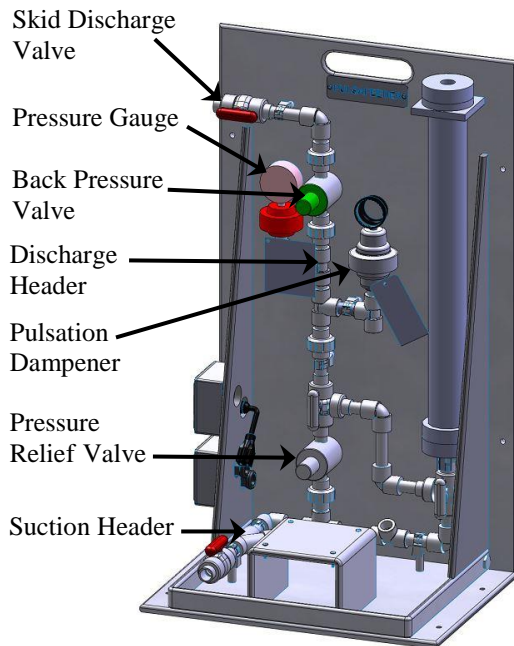

*Figure 12*  
*Skid Component Locations*

### Pressure Relief Valve (PRV)

A Pressure Relief Valve must always be used with a chemical metering system that uses a positive displacement pump. This device is designed to protect the pump and system from over-pressurization, and it must be set to relieve at the maximum allowable pressure for the weakest point in the total system. This may be in your piping on the discharge side of the skid. **It is extremely important that you determine this pressure limitation and set the PRV accordingly.**

Most Pulsafeeder skid systems include a Pressure Relief Valve (PRV) and suction header where the PRV is directly connected from the discharge header to the suction header. If your skid system does not include a suction header, or if you are providing your own PRV, relief flow from the pressure relief port on the PRV must be directed to either the suction source or a separate receptacle. This is usually done with tubing.

### Back Pressure Valve (BPV)

The Back Pressure Valve enables the pump to work against a constant pressure and will also function as an anti-siphon valve. This is especially important for injection systems that operate at low pressures or where there may be fluctuations in injector system pressure. The BPV is typically set at 50 PSIG, but a lower set pressure may be required depending upon your pump and your system configuration. Refer to Table 1 in the Appendix of this manual for recommended pressure settings.

Installation, Operation and Maintenance Manual

**Pulsation Dampener**

Positive displacement pumps will create pressure pulsations in the discharge line which can be damaging to piping or system components. A pulsation dampener utilizes an air chamber separated from the pumped liquid by a diaphragm to cushion any pulsation(s) and provide a steady flow.

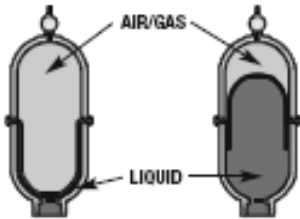
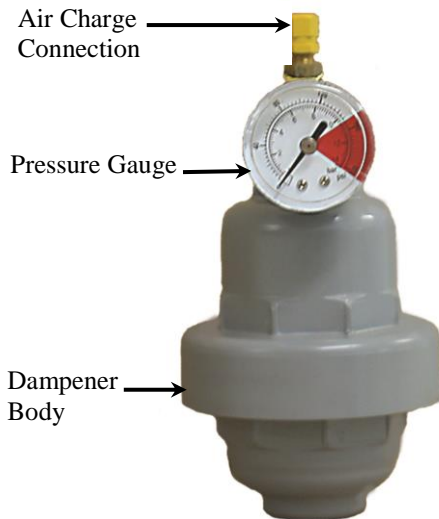

Figure 13

Pulsation Dampener Internals

The air pressure in the Pulsation Dampener is generally set at 80% of the system operating pressure. If system pressure is lower than the Back Pressure Valve setting, use 80% of the Back Pressure Valve setting.



Air can be introduced to the Pulsation Dampener through the air fitting. This fitting can also be used to adjust and to relieve air pressure. It is strongly recommended that the pressure in the air chamber be completely relieved prior to performing any maintenance on the skid system. An air pressure gauge is provided on the Pulsation Dampener itself to indicate pressure present in the air chamber.

When the pump is shut off, the Pulsation Dampener and discharge piping will have residual pressure in it. Use extreme caution when opening valves to drain and/or vent the system since you must bleed off this residual pressure.

Figure 14

Typical Pulsation Dampener  
(courtesy Blacoh)

**Setting Valves**

Prior to setting the Pressure Relief Valve (PRV) and the Back Pressure Valve (BPV), thoroughly review and familiarize yourself with the instructions for valve operation.

Prior to setting valve pressure, the skid discharge piping should be filled with liquid.

1. Set Pulsation Dampener air pressure (see above).
2. Adjust PRV and BPV to their lowest pressure settings (fully open).
3. Adjust Skid Discharge Valve and/or system piping to allow venting from the skid discharge piping.
4. With pump primed, run pump until air is evacuated from the skid discharge piping.
5. Shut off pump.



## Installation, Operation and Maintenance Manual

---

### Set Pressure Relief Valve (PRV)

Refer to Table 1 in the Appendix, Page 23, for recommended PRV pressure settings.

With Pressure Relief Valve and Back Pressure Valve fully open (lowest pressure setting),

1. Close Skid Discharge Valve.
2. Start pump, monitor Skid Discharge Gauge pressure. It should pulse slightly. On most Pulsafeeder Pre-Engineered Skid systems, relief flow should be passing through the PRV into the suction header. If your Pressure Relief Valve is configured differently, monitor relief flow appropriately.
3. Gradually increase pressure at PRV until the Skid Pressure Gauge reads the maximum allowable pump and/or system pressure at the highest pulsation pressure.
4. Shut down pump.
5. PRV is now set.

### Set Back Pressure Valve (BPV)

Refer to Table 1 in the Appendix, Page 23, for recommended BPV pressure settings.

After the Pressure Relief Valve has been set, check to see that the Back Pressure Valve is fully open (lowest pressure setting).

1. Adjust Skid Discharge Valve and/or system piping to allow free discharge from the skid discharge piping. Capture free discharge in an appropriate manner.
2. Start pump, monitor Skid Discharge Gauge pressure.
3. Gradually increase pressure at BPV until correct pressure is indicated on the Skid Discharge Gauge.
4. Shut down pump.
5. BPV is now set.
6. Re-adjust system discharge piping/tubing to enable flow into the served process.

**CAUTION**

Care must be taken to channel any free flow from the pumping system into an appropriate receptacle. Eliminate any possibility of splashing or spraying or spillage. Always wear suitable protective equipment (gloves, safety goggles/glasses, coveralls, etc.) when working with or around chemical dosing systems.

Check all system piping/tubing connections to ensure that they are properly tightened (hand-tight for plastic fittings) and leak-free.

Pumping system is now ready for operation.

## Installation, Operation and Maintenance Manual

## Flow Calibration

Chemical metering systems are designed to provide chemicals to a process at precise flow rates. Metering pump output (flow rate) can be set as a function of both stroke length and stroke frequency. A Calibration Column is used to determine pump flow rate and to enable flow rate adjustments. The column must be filled with the dosing chemical prior to performing the calibration.



Use extreme care when handling chemicals.  
Avoid any spray, splatter or spilling.  
Always wear appropriate protective clothing.

A description of the Calibration Column and the calibration procedure is shown on Page 20. Review this before proceeding with the next steps.

### Filling Calibration Column

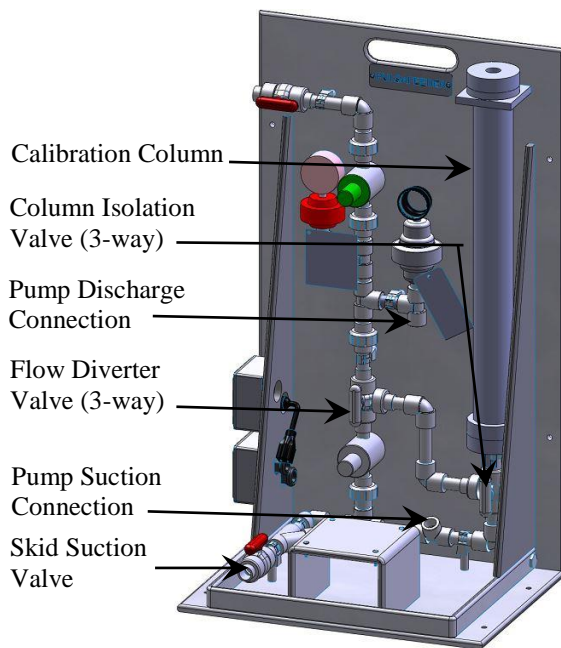

Figure 15

For a skid system with a cross-connect, the Calibration Column is filled by the pump. See Figure 15, at left.

1. Turn the Column Isolation Valve to allow flow from the cross-connect into the Calibration Column.
2. Then turn the Flow Diverter Valve to direct flow from the Discharge Header through the cross-connect and into the Calibration Column.
3. Once the liquid level in the Calibration Column reaches slightly above the topmost scale mark, turn the Flow Diverter Valve to re-direct flow into the system. Do not overfill.
4. Close Column Isolation Valve.
5. Calibration Column is filled and ready for the calibration procedure.

Note: While the Calibration Column is being filled in this manner, dosing chemical will not be provided to the served process.

## Flooded Suction



Use extreme care when handling chemicals.  
Avoid any spray, splatter or spilling.  
Always wear appropriate protective clothing.

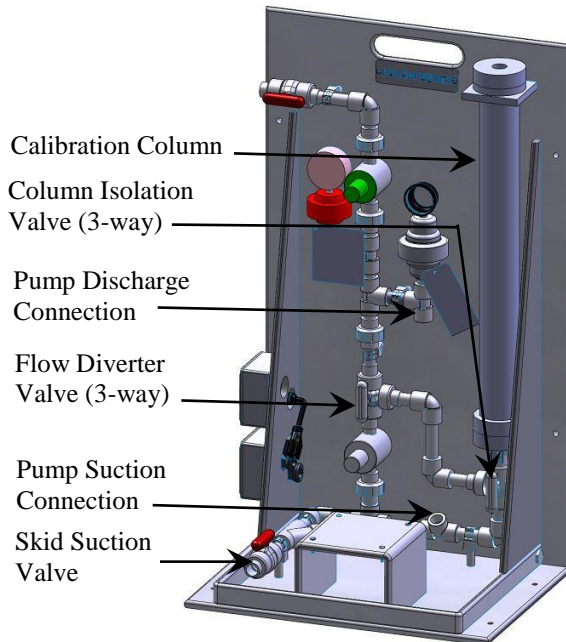

For systems with flooded suction  
(see Figure 3, Page 7):

1. Open Column Isolation Valve
2. Liquid level in the column should rise to the level in the suction source. This may be higher than the top of the column, so prevent overflow by closing the Column Isolation Valve when the liquid level in the Calibration Column reaches slightly above the top scale mark.
3. If the liquid level in the suction source is lower than the top scale mark, close the Column Isolation Valve and add liquid through the top of the column to a point slightly above the top scale mark.

*Figure 16*

## Suction Lift

For systems on suction lift (see Figure 4, Page 8):

1. Partially fill the Calibration Column through the top.
2. Open the Column Isolation Valve briefly to vent any air that may be present in the suction header piping. Close the Column Isolation Valve.
3. Fill the Calibration Column to slightly above the top scale mark.

Calibration Column is filled and ready for the calibration procedure.

Installation, Operation and Maintenance Manual

**Flow Calibration Procedure**

The Calibration Column is filled to slightly above the top mark of the scale. The pump is then run in the system while being fed from the Calibration Column. After a 30 second time period, the liquid level reading on the scale will be a direct readout of the pump flow rate in US Gallons/hr. (Note that a milliliter scale is also shown on the Calibration Column)

With the pump running in the system

1. Open the Column Isolation Valve so that the column feeds into the suction header, and immediately close the Skid Suction Valve (see Figures 15 and 16)
2. Observe the liquid level in the Calibration Column. When it reaches the top scale mark, begin timing.
3. Allow 30 seconds to pass.
4. Open the Skid Suction Valve and immediately close the Column Isolation Valve
5. Read pump output flow rate directly on the scale in US Gallons/hr.

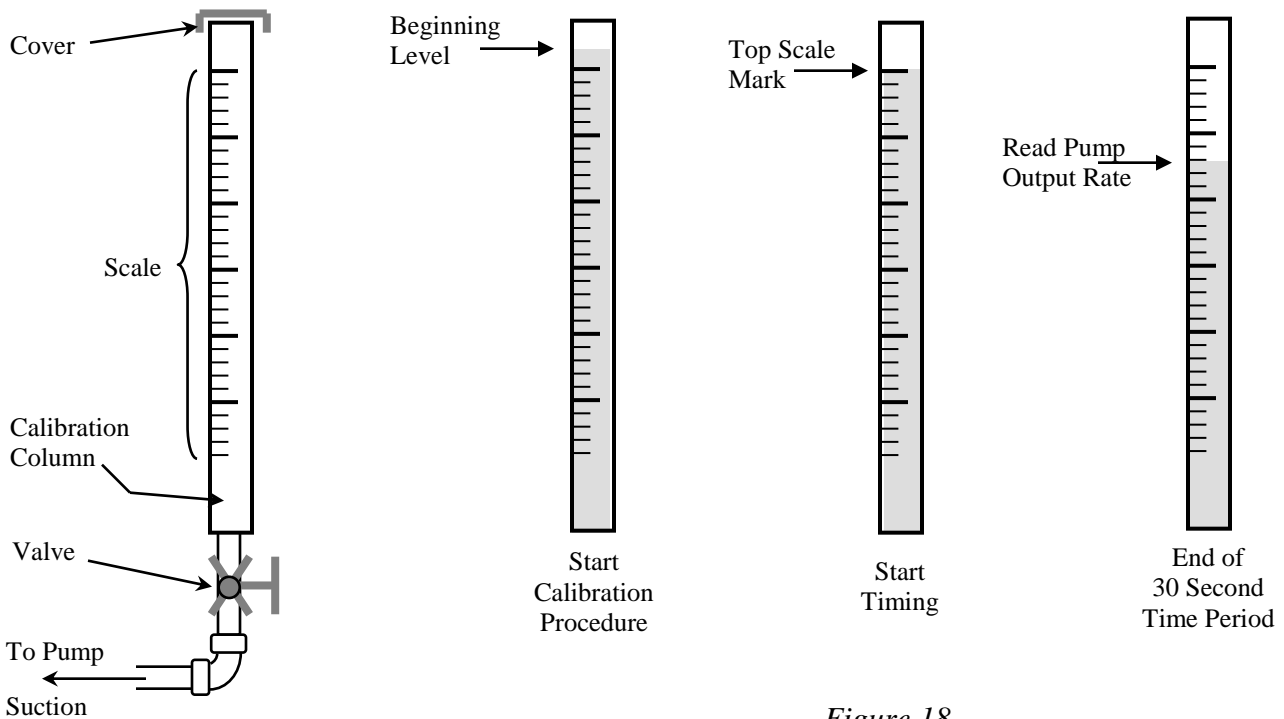

*Figure 17  
Calibration Column*

*Figure 18  
Liquid Levels During Calibration*

Once the calibration is complete, compare the reading to the desired rate for your system. Refer to your pump operation manual and adjust flow rate up or down accordingly (this is usually done by changing stroke frequency). After pump adjustment is made, repeat calibration procedure. Continue until the desired flow rate is achieved.

---

## Installation, Operation and Maintenance Manual

---

### Routine Maintenance

Before performing any maintenance on your skid system or pump,



**Skid components, pump(s) and your process piping may be under pressure!**

Prior to working on any portion of the Skid System, disconnect pump(s) from power supply, de-pressurize the entire system and drain chemicals from the lines. Flush and neutralize as necessary.

Always wear suitable protection (gloves, safety glasses/goggles, etc.)

Routine maintenance will depend upon your service requirements: dosing chemical(s) being handled, environmental conditions, duty cycle(s) of pump(s), etc. When working on any component of your system, i.e., pump, valves, pulsation dampener, refer to the Installation, Operation and Maintenance Manual for that particular item. Some operational and maintenance checks that need to be performed are:

**Strainer** – A Y-strainer is furnished in the suction header for the skid. Check this for the presence of trapped solids and clean as necessary. Recommend weekly check.

**Piping/Tubing Integrity** – Routinely check piping, tubing, isolation valves and connections for leaks. Replace tubing as necessary. Recommend weekly check.

**System Operation** – Perform flow calibration regularly to ensure that dosing chemical is being added at the proper rate. Recommend monthly.

**Pressure Relief and Back Pressure Valves** – Check to ensure that bolts are tight. Recommend monthly. Diaphragms should be replaced on an annual basis.

**Pulsation Dampener** – Check air pressure versus recommended set point. Recommend weekly.

**Calibration Column** – If handling sticky chemicals, may require cleaning to view liquid level inside. Perform as necessary.

## Installation, Operation and Maintenance Manual

**Troubleshooting Guide**

<b>Problem</b>	<b>Possible Cause</b>	<b>Remedy</b>
Pump doesn't deliver product	Air entering suction line	Check fittings for tightness Check integrity of tubing Check level in suction source – must be above foot valve at inlet
	Air trapped in suction line	Re-configure suction line to eliminate air pocket(s)
	Suction line kinked or clogged	Inspect, replace tubing
	Chemical source empty	Refill, re-prime pump
	Pump not primed, air/gas in system	Re-prime pump
	Air/gas bubbles forming in chemical	Reduce suction lift or change to flooded suction Consider chemical storage temperature
	Strainer clogged	Check strainer, clean
	Pressure Relief Valve open	Check Pressure Relief Valve integrity Check Pressure Relief Valve setting
Piping Vibration/chatter	Pulsation Dampener malfunction	Check Pulsation Dampener integrity Check Dampener air pressure
Injection rate too high, too low	Pump output setting incorrect	Perform flow calibration
	Chemical concentration too high, low	Adjust chemical source strength
	Siphoning into well or low pressure point	Add Back Pressure Valve at injection point
	Injector clogged, scaled, restricted	Check injector for solids or corrosion Clean as necessary or replace
Injection rate varies	Back Pressure Valve	Check Back Pressure Valve integrity Check Back Pressure Valve setting
Tubing failure	Sunlight/UV exposure	Change to UV-resistant tubing
	Corrosive attack	Determine material compatibility, change as necessary
Leaky fittings	Loose fittings	Tighten fittings – plastic fittings should be hand-tight only
	Corrosive attack	Determine material compatibility, change as necessary

If problem(s) persist, call your Pulsafeeder representative. We're here to help.

Installation, Operation and Maintenance Manual

Table 1 – Factory Pre-sets for Components							
Pump, if furnished with Skid, and System Description				Component Settings at Factory			
Pump Data			System Configuration	Calibration Column Size	Back Pressure Valve	Pressure Relief Valve*	Pulsation Dampener Air Pressure**
Size	GPD	PSI					
K2	3	300	Standard	200 mL	50 PSI	150 PSI	120 PSI
12	5	250					
B2	5						
2	6						
C2	6						
C3	10						
33	12						
D3	12						
F4	20						
H4	41						
A2	6						
13	12						
B3	12						
34	22						
D4	22						
G4	42						
K5	60						
H5	76						
3	12	100	Standard	200 mL	50 PSI	100 PSI	80 PSI
A3	12						
K3	14						
4	24						
14	24						
B4	24						
64	30						
44	44						
E4	44						
G5	96						
H6	120						
54	30						
C4	48						
J7	240						
K7	192						
H7	240						
H8	600						
						HF (High Flow)	1000 mL
						100 PSI	
						80 PSI	60 PSI
					25 PSI	50 PSI	40 PSI
					50 PSI	80 PSI	60 PSI
					25 PSI	50 PSI	40 PSI
					20 PSI	35 PSI	25 PSI
						30 PSI	

Note:

\*Pressure Relief Valve setting at factory is based upon pump and skid components furnished.

**You must determine your system pressure limit. If less than the factory pre-set, you must re-set the Pressure Relief Valve accordingly.**

\*\*Pulsation Dampener air pressure values shown are factory pre-sets.

**You must re-set the Pulsation Dampener air pressure to 80% of your system pressure or 80% of the Back Pressure Valve setting, whichever is greater. Never set higher than 120 PSI.**