

# MINI-TROL IF Reverse Osmosis Controller

## *Installation Maintenance Repair Manual*



Advantage Controls  
4700 Harold-Abitz Dr.  
Muskogee, OK 74403  
Phone: 800-743-7431  
Fax: 888-686-6212  
www.advantagecontrols.com  
email: support@advantagecontrols.com

08/2024

# Installation

1. Confirm that the controller is configured for the proper voltage: 120, 240 or 24-volt. See ID label, as well as the label located on top of the transformer designating voltage. (See Fig. 1)
  2. The RO pump motor or motor starter and the solenoid valves must be of the same voltage: 120, 240, or 24-volt.
  3. Confirm that the (3) input signals – pressure switch, tank level switch, and pretreat switch – are all of the same configuration, normally open **OR** normally closed.
  4. Confirm the desired jumper settings for your operation. The jumpers are factory set to Position B Auto Reset (disabled), Pressure Fault Retry (disabled), Tank Full restart time delay (2 seconds), Input contact type (NC, open to operate), and flush on tank full. If you wish to change any jumper functions, move that jumper to Position A. (See Table on next page.)
  5. If a wire harness is provided with this controller, skip this section and proceed to Step 6. If wiring to the controller is required, proceed as follows:
    - A. Remove the enclosure cover.
    - B. Mark and drill necessary electrical entry holes in the empty enclosure.
    - C. Terminate necessary wiring to the terminal strips as required. (See Fig. 1) Each terminal is labeled for the proper connection. Terminal strip P1 is high voltage for power, motor, inlet, and flush solenoid. Utilize proper 3 conductor wire for the appliance.
-  **WARNING:** The controller is rated for maximum 20-amp total load. Terminal strip P2 is low-voltage for input signals from tank full, pressure fault, and pretreat lockout. Use small gauge 2 conductor cable for these wire connections.
6. Position and mount the enclosure in the desired location.
  7. Connect all wiring to the appropriate appliances. **Do not connect to the power source at this time.**
  8. Reassemble the enclosure, be sure to coil and leave some slack wire inside the enclosure.
  9. Turn the power switch to the OFF position.
  10. Connect the power wire 120, 240, or 24-volt to its source.
  11. Proceed to turn the power switch On and test the completed unit as necessary.
  12. Observe the status LED color to confirm system status.

Figure 1



JUMPER	POSITION B	POSITION A
J4	AUTO RESET DISABLED	AUTO RESET ENABLED
J5	RETRIES DISABLED	RETRIES ENABLED
J6	2-SEC RESTART	15-MIN. RESTART
J7	N.O. SWITCHES	N.C. SWITCHES
J8	TANK FULL FLUSH	24-HOUR FLUSH

**WARNING:** All switch inputs must be dry contact only. If voltage is applied to these inputs, damage to the controller will result. For power with neutral and hot leads, L1 is hot and L2 is neutral.

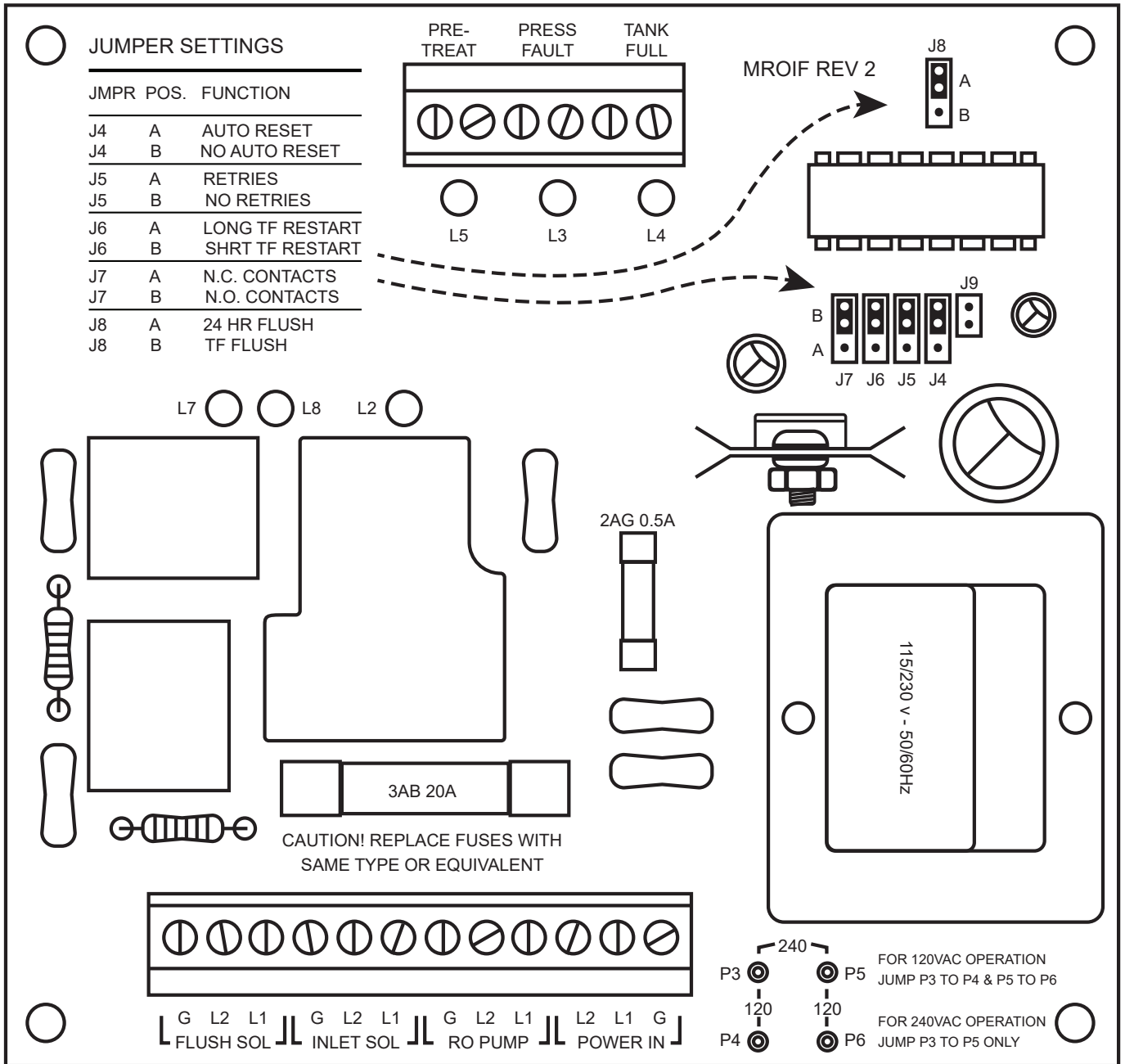
# System Operation

When the power switch is turned ON, the status LED will light Green, the inlet valve will OPEN and, after a 5-second delay, the RO pump will start.

Under normal operation, the RO unit will run until: (A) the storage tank is full (status LED Amber) or (B) Pretreat lockout has occurred (status LED flashing Green). When A or B has cleared, after a time delay, the RO unit will restart, and the status LED will return to Green. Jumper setting J-6 selects a 2-second or 15-minute tank full restart time delay.

Upon an alarm signal for Pressure Fault, the status LED will turn RED, the RO pump will stop, and the inlet valve will close.

If jumper J-4 and J-5 are in Position B (disabled), the status LED will flash RED and the RO unit will not restart until the Power Switch has been manually cycled OFF and then ON to reset the unit.



If jumper J-4 is in Position A (auto reset), every 60 minutes the controller will check the pressure fault and either stay OFF or START accordingly.

If J-5 is in Position A (pressure fault retry), the RO unit will attempt to restart after 30 seconds, then 5 minutes, then 30 minutes.

If the pressure alarm has not cleared after the third attempt, the RO unit will remain off until manually reset.

If jumper J-4 and J-5 are in Position A, after a pressure fault condition, the RO unit will continually attempt to restart after each 60-minute cycle until the pressure switch input has cleared.

If jumper J-8 is in Position A, the RO unit will flush every 24 hours of elapsed time. If jumper J-8 is in Position B, the RO unit will flush on tank full. During Flush, the inlet and flush valves are open and the RO pump is On. The flush time is 5 minutes. The status LED will double-flash AMBER.

 <b>CAUTION</b> 
1. There are live circuits inside the controller even when the power switch on the front panel is in the OFF position. Never open the front panel without first disconnecting power from the outlet. Prewired controllers are supplied with an 8 foot, 18 AWG power cord with USA style plug. A #1 Phillips driver is required to open the front panel.
2. Low voltage signal wires (probes, flow switch, water meter, etc.) should never be run in conduit with high voltage (like 115VAC) wires.
3. Never attempt to land connections to the controller without first disconnecting power from the outlet.
4. Do not block access to disconnect power during mounting and installation.
5. The controller should be connected to its own isolated circuit breaker, and for best results, the ground should be a true earth ground, not shared. Any attempt to bypass the grounding will compromise the safety of users and property.
6. The electrical installation of the controller must be performed by trained personnel only and conform to all applicable National, State and Local codes.
7. Operation of this product in a manner not specified by the manufacturer may result in damage to equipment or persons.
8. Avoid mounting in locations that expose the controller to direct sunlight, vapors, vibration, liquid spills or extreme temperatures; less than 0°F (-17.8°C) or greater than 120°F (50°C). EMI (electromagnetic interference) from radio transmissions and electric motors can also cause damage or interference and should be avoided.







# Get the Advantage in Water Treatment Equipment

Advantage Controls can give you the *Advantage* in products, knowledge and support on all of your water treatment equipment needs.

- Cooling Tower Controllers
- Boiler Blow Down Controllers
- Blow Down Valve Packages
- Bleed Valves
- Water Meters
- Metering Pumps
- Corrosion Coupon Racks
- Solution Tanks
- Solid Feed Systems
- Bypass Feeders
- Filter Equipment
- Glycol Feed Systems
- Pre-Fabricated Systems

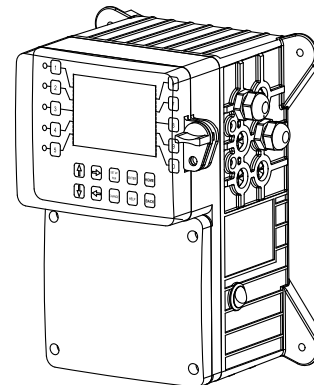
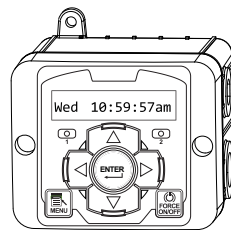
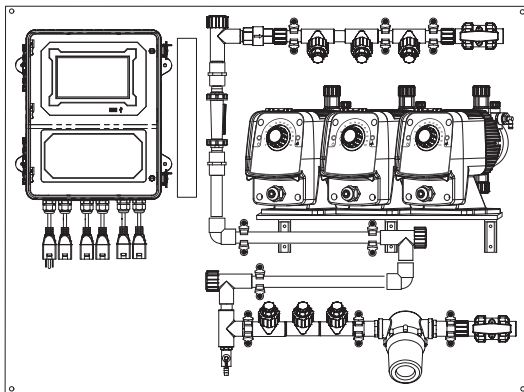
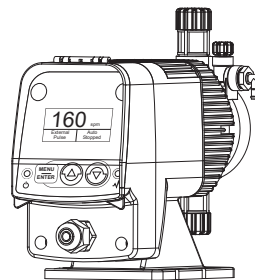
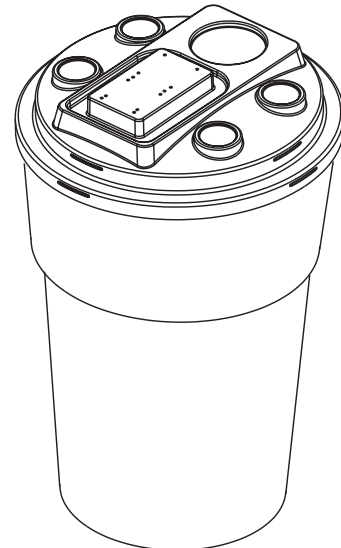
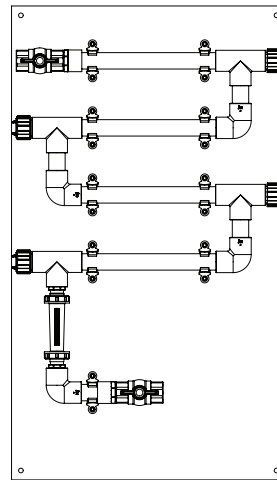
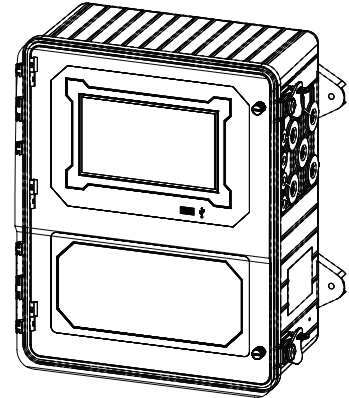
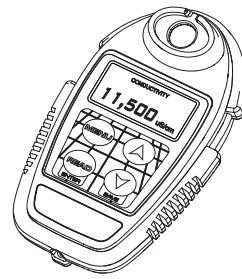

Get the Advantage

