

# Analog

# Tower Controller

***Installation  
Maintenance  
Repair  
Manual***

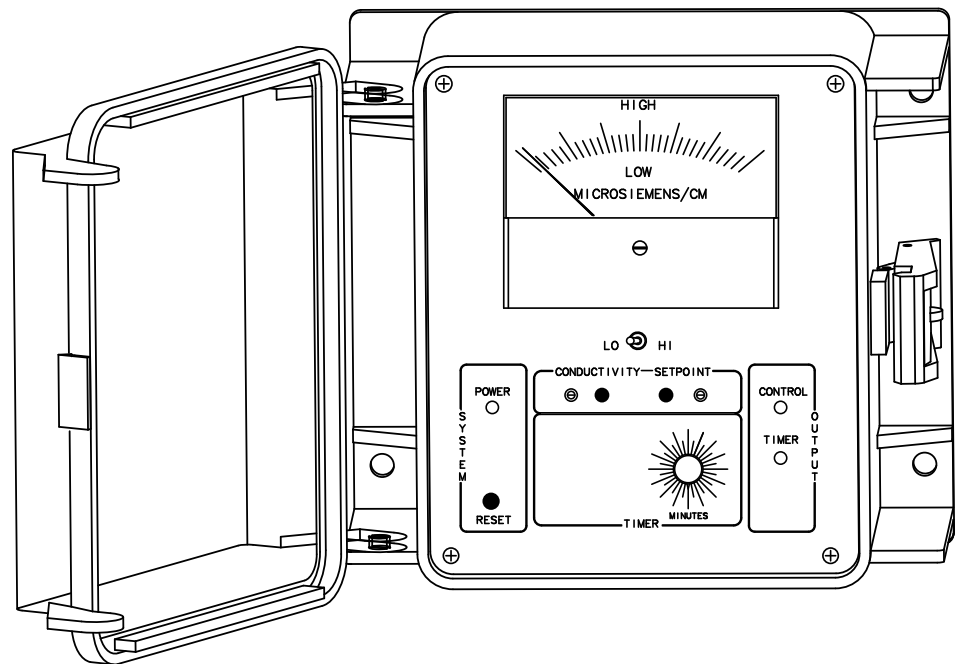

Advantage Controls  
P.O. Box 1472  
Muskogee, OK 74402  
Phone: 800-743-7431  
Fax: 888-686-6212  
[www.advantagecontrols.com](http://www.advantagecontrols.com)

# Analog Cooling Tower Instruction & Maintenance Manual Table of Contents

Contents	Page No.
I. Introduction .....	3
Model Numbering .....	3
Description of Unit .....	3
II. Installation	
Electrical Installation .....	4
Mounting .....	5
Electrode Installation .....	5
III. Front Panel Description .....	7
IV. Model AM and 2-AM Start Up	
A. System Start Up.....	8
B. Calibration.....	8
C. Adjusting the Set Point .....	8
V. Model A and 2-A Start Up	
A. System Start Up.....	8
B. Calibration.....	9
VI. Maintenance .....	9
Electrode Cleaning Procedures .....	9
VII. Troubleshooting .....	10
VIII. Warranty & 30 Day Billing Memo Policy .....	11

## I. Introduction

Model A, AM, 2-A and 2-AM controllers are analog style controllers for the control of conductivity in recirculating water applications, such as cooling towers. There are two basic styles of analog cooling tower conductivity controllers differentiated by the style of display used.

**1. Analog Dial Display** - Analog dial display units have a dial display for setting and control of the conductivity. Dial models covered in this manual include: **A** and **2-A**.

**2. Analog Needle Meter Display** - Analog needle meter display units provide a needle meter for setting and displaying the conductivity. Needle meter models covered in this manual include: **AM** and **2-AM**.

### Model Numbering

Standard analog controllers have several optional features available. Your unit may be supplied with one or more of the options that are described in this manual. To determine what features apply to your unit, check the model number label located on the controller enclosure.

#### Optional Features

This list represents our most popular options.

<b>1</b>	Pump lockout timer, 0-90 minutes	<b>H</b>	No output cords
<b>2</b>	Pulse timer, 0-150 seconds	<b>K</b>	Percent Timer
<b>3</b>	Conduit connections	<b>K-2</b>	Switch selectable between Pulse or Percent timer
<b>4</b>	230V 50/60Hz	<b>M</b>	Removes clear cover
<b>5</b>	Mounted flow switch	<b>O</b>	Terminal strip connection for bleed solenoid valve
<b>6</b>	Recorder output (0-1mA)	<b>P</b>	Lockout bleed when Pulse timer activates
<b>7</b>	Additional probe cable	<b>Q</b>	Optional conductivity scales
<b>8</b>	Additional output cord	<b>R</b>	Molex connector for probe
<b>9</b>	Time delay relay	<b>V</b>	Normally open and closed outputs for bleed relay
<b>A</b>	Tank mount electrode	<b>W</b>	25 amp relay output
<b>B</b>	Stainless steel leads on electrode	<b>X</b>	Hi / Low alarm
<b>C</b>	4-20mA output non isolated	<b>Z</b>	Dry contact for control output
<b>D</b>	Reverse set point		
<b>F</b>	Alternate probe tee fittings		
<b>G</b>	Omit electrode		

### Description of Unit

The Advantage Controls analog controllers are conductivity based controllers for recirculating water systems. The set point and conductivity reading are displayed on the dual range analog front panel meter of the Model AM and 2-AM and on the front panel dial of the Model A and 2-A. The switch selectable dual scale allows greater control precision. When the conductivity of the system water passes the operator selected set point the unit will energize the control relay. Once the conductivity goes back past the set point plus/minus the differential, the relay will be de-energized.

An LED indicator is supplied for system POWER and one marked CONTROL indicates when the control relay is energized. Unit's with an optional feed timer will have an LED for the timer.

A front panel push button switch marked TEST is provided. When the switch is depressed, the control simulates an approximate “full” scale conductivity. This allows the user to determine (1) if the unit is working properly, and (2) if the controlled devices are functioning properly.

**Note:** If a flow switch is present, the controller must have flow for the relays to activate even with the Test Switch.

### **Optional Feed Timers**

- 1. Limit Timer-** This timer activates simultaneously with the bleed. The timer limits the amount of time the relay output will be on during a bleed cycle, preventing chemical overfeed. The timer’s standard range is 0-90 minutes.
- 2. Pulse Timer-** This timer starts when a dry contact is received from a make-up water meter (supplied separately). The timer’s standard range is 0-150 seconds.
- 3. Percentage-** The feed relay is on for a percentage of a continuously repeating cycle time. The standard timer can be set from 0-100% of a 10 minute cycle time.

## **II. Installation**

### **Electrical Installation**

The standard units have a voltage regulated internal power supply capable of operating in the range of approximately 105 to 135 VAC. Use a supply voltage of 110 to 120 VAC for best results. Relay outputs are protected by a replaceable fuse.

Prewired units are supplied with a 18 AWG cable with 3-wire grounded USA 115 volt plug for incoming power and 18 AWG 3-wire grounded receptacle cords for all control relay outputs.

- WARNINGS:**
- 1. The controller should be connected to its own isolated circuit breaker and for best results the ground should be a true earth ground not shared. Wiring must be done according to all applicable local codes.**
  - 2. Power (line voltage) must be disconnected while making any connections. If power is supplied to the unit, line voltage will be present.**
  - 3. Low voltage signal wires (probes, flow switch, water meter etc...) should never be run in conduit with high voltage wires.**

### **Optional Conduit Connections**

Conduit units are predrilled at the factory and supplied with conduit knockouts for easy hard wiring to supplied connectors located in the lower section of the controller. Remove the panel screws for access.

## 2-A and 2-AM Connections (Revised April-2004)

### Relay Card

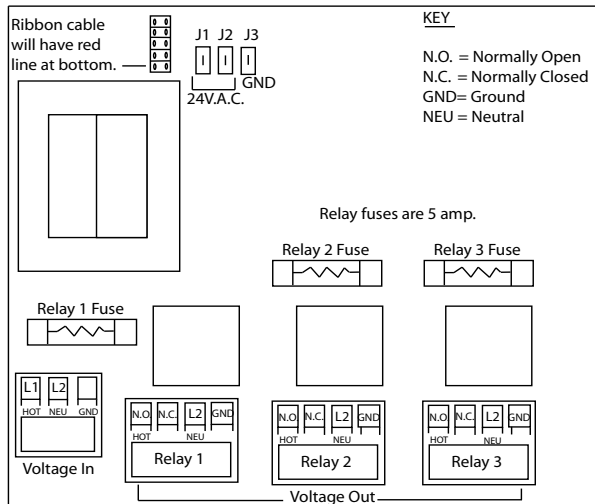

### Control Card

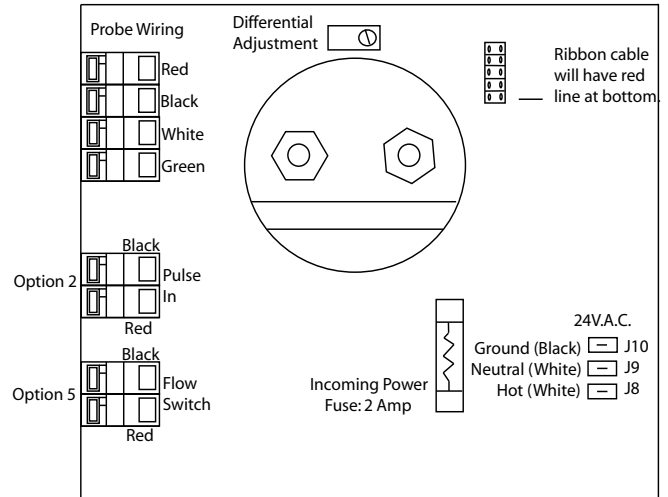

## Mounting

Select a mounting location that provides the operator easy access to the unit and a clear view of the controls through the cover of the controller. The location should be in proximity to grounded electrical connections, the needed sample line plumbing, and on a stable vertical surface.

**WARNING:** Avoid locations that expose the controller to direct sunlight, vapors, vibration, liquid spills or extreme temperatures; less than 0°F (-17.8°C) or greater than 120°F (50°C). EMI (electromagnetic interference) from radio transmissions and electric motors can also cause damage and should be avoided.

## Electrode Installation

The standard probe and optional flow assembly for cooling tower installations is constructed of schedule 80 PVC and supplied with 3/4" slip fittings for installing into a sample line. To insure proper operation the sample line must have a flow rate of 3-10 gpm. Inlet pressure must be higher than outlet pressure in order for water to flow past the electrode(s). The probes are temperature compensated for increased accuracy.

- NOTES:**
1. Install an isolation valve on either side of the flow assembly so electrodes can be easily removed for maintenance.
  2. A line strainer is recommended upstream from the probes to protect against fouling and damage.
  3. Units with a flow switch require the needed flow rate to operate the relay outputs.

- WARNINGS:**
1. Electrodes are O-ring sealed, which if damaged will cause a leak.
  2. Do not exceed a water temperature range of 32°F to 140°F.
  3. Do not exceed a maximum pressure of 150 psi.

## Typical Installation

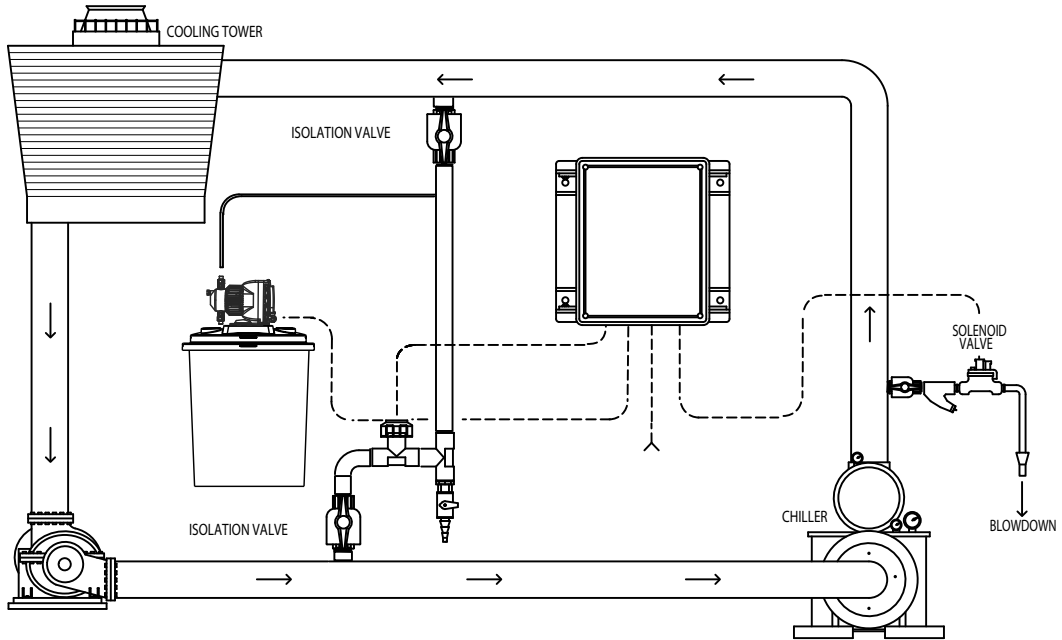

## Optional Flow Switch Assembly

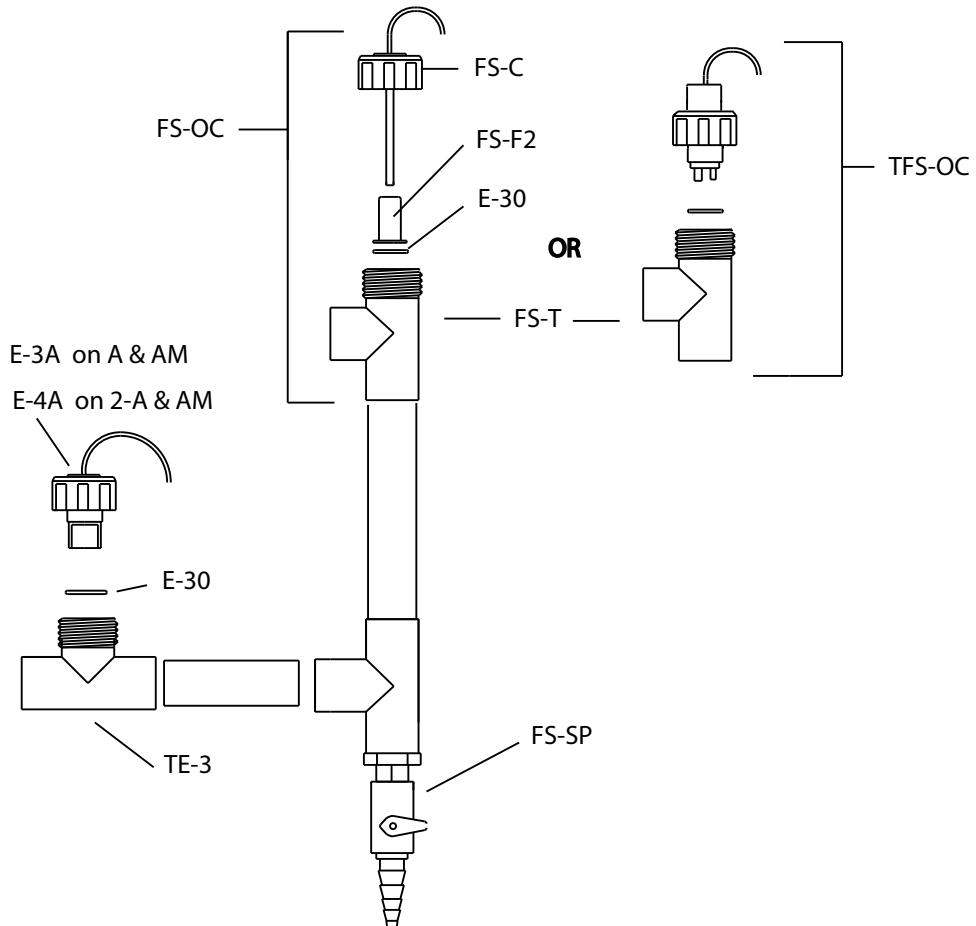

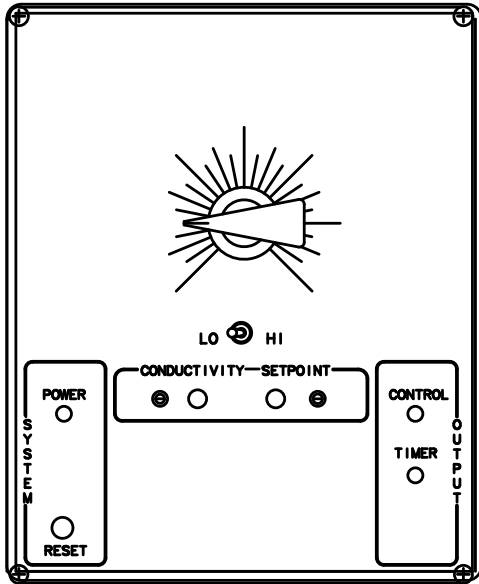

**Model 2-A**

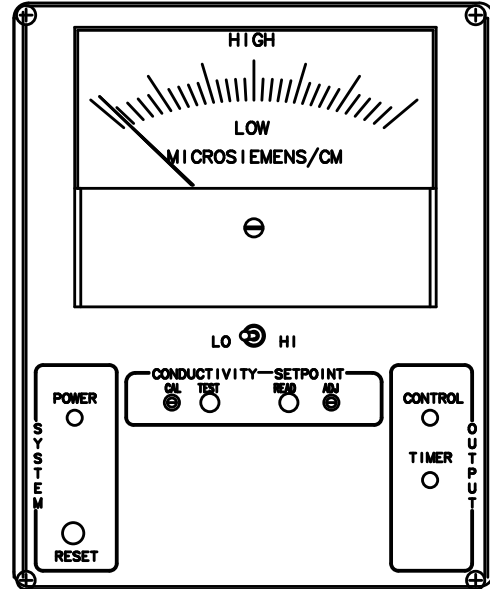

**Model 2-AM**

### III. Front Panel Description

#### Model AM & 2-AM

**CONDUCTIVITY METER:** The large needle display provides a constant reading of the conductivity. The set point is displayed when the set point read button is pushed in.

#### Model A & 2-A

**CONDUCTIVITY DIAL:** Used to adjust the set point and to determine the current conductivity level. To determine the current conductivity, rotate the dial until the CONTROL LED turns on. The dial reading at this point equals the current conductivity reading.

**LO/HI SCALE switch:** Used to select the Low or the High scale as the operating range.

- Notes:**
1. **Unit is factory calibrated for the high scale.**
  2. **The high and low scale positions use independent calibration resistors. It is therefore necessary to re-calibrate the unit when changing scales.**

**POWER LED:** Lights whenever power is supplied to the controller.

**CONDUCTIVITY CAL:** Used to change the current conductivity reading. To use, adjust the screw to the left or right to achieve the conductivity you desire.

**TEST button:** Used to test the conductivity circuit. When the switch is pushed and held in the down position, it simulates a full scale conductivity reading.

**SET POINT READ button:** Depress push button switch to read the set point.

**SET POINT ADJ screw:** Used in conjunction with READ switch to adjust set point of controller.

**CONTROL LED:** Lights whenever the conductivity exceeds the set point.

## **IV. Start Up - Models AM and 2-AM**

### **A. System Start Up**

1. Install the unit per the installation drawing on Page 6 of this manual.
2. Connect all externally controlled devices and supply power to the unit.
3. Choose the scale to be used (high or low) and place the scale switch in the proper position.
4. Calibrate the unit. If you change scales, always recalibrate full scale with the test button pushed.

### **B. Calibration**

Before attempting to calibrate the unit, insure that electrode is properly cleaned per the information on Page 9.

1. Use a reliable test method to determine the conductivity of the system water. Insure that the sample used is the same as what is going through the probe tee. If an alternate conductivity tester is not available, a solution of known conductivity can be used. Do not allow the electrode to touch the bottom of the sample container.
2. Turn the CALibration screw left or right until the reading on the meter is the same as the reading achieved in step 1. The calibration pot is a multi-turn pot and may require several turns to changes the reading.

### **C. Adjusting the Set Point**

1. Hold down the SET POINT READ button.
2. Turn the SET POINT ADJ screw to achieve the desired set point on the display.
3. Release SET POINT READ switch.

## **V. Start Up - Models A and 2-A**

### **A. System Start Up**

1. Install the unit per the installation drawing on Page 6.
2. Connect all externally controlled devices and supply power to the unit.
3. Select the scale to be used (high or low) and place the scale switch in the proper position.
4. Calibrate the unit to known conductivity value .



## B. Calibration Instructions

Before attempting to calibrate the unit, ensure that the electrode is properly cleaned.

1. Use a reliable test method to determine the conductivity of the system water. Insure that the sample used is the same as the water going through the probe tee. If an alternate conductivity tester is not available, a solution of known conductivity can be used. Do not allow the electrode to touch the bottom of the sample container
2. Set the large dial on the front of the Model A or 2-A controller to the reading achieved in step 1.
3. If the CONTROL LED is on, rotate the CALibration adjustment screw counterclockwise until the light just goes out.
4. If the CONTROL LED is off, rotate the CALibration adjustment screw clockwise until the control light just comes on.

## C. Adjusting the Set Point

Set the large dial to the set point desired. If solenoid valve is on, allow system to bleed down. If not, press the TEST switch to activate the solenoid valve.

## VI. Maintenance

The only required maintenance for normal uninterrupted operation of your Advantage analog cooling tower controller is cleaning the electrode.

After initial start up, it is a good idea to clean the electrode weekly until a schedule based on need has been developed. Since each application is unique, it is difficult to estimate the required frequency of cleaning. The first cleaning should take place after about one week of the system being on line.

To determine the required cleaning frequency, record the reading on the controller before the electrode is removed for cleaning. After cleaning, record the new reading. If a change is observed in the two readings, the electrode was dirty. The more significant the change, the dirtier the electrode. If no change occurs, cleaning needs to be done less often.

### Electrode Cleaning Procedure

1. Record the current conductivity reading.
2. Turn off water flow through the electrode loop, bleed pressure from the line and remove electrode.
3. Use a clean cloth and a mild cleaning solution to remove loose dirt etc., from the flat surface of the electrode.
4. If deposits such as scale are attached to the electrode surface, use a more aggressive cleaning approach. There are several ways to do this, the preferred method is the one that is easiest for the user.
  - a. Use a mild acid solution to dissolve deposits.
  - b. Use a pocket knife with a flat blade to scrape across the probe surface *perpendicular* to the carbons.

- c. Lay a piece of sandpaper (200 grit or finer ) on a flat surface such as a bench top. The electrode can then be “sanded” to remove stubborn deposits.
- 5. Reinstall the electrode in the system. After the reading stabilizes, calibrate the unit to a reliable test reading.

Many times an electrode can appear to be clean, but the unit still cannot be calibrated. If this is the case use the TEST switch to determine that the unit itself is working properly. (See page 9 of this manual.)

If the controller checks out, but still cannot be calibrated, use one of the more aggressive electrode cleaning procedures listed in step 4 above. Recheck the calibration after completion of this procedure. If no change was observed in the reading, replace the electrode. If a change occurred but the unit still will not calibrate, repeat procedure as many times as necessary.

## VI. Troubleshooting

The Advantage Models 2-A or 2-AM controllers are designed to provide many years of trouble free operation. Should a problem occur, refer to the following chart to help identify the problem.

<b>SYMPTOM</b>	<b>POSSIBLE CAUSE</b>	<b>SOLUTION</b>
False reading	Bad or dirty electrode Out of calibration	Clean, as needed Calibrate unit
Will not calibrate	Dirty electrode Faulty electrode Faulty wiring to electrode Out of Calibration	Clean electrode Replace controller or electrode as needed Calibrate unit
No system power	Power source Check fuse (A & AM)	Check power source Replace as needed
No output	Check flow switch Check fuse	Clean or replace Replace as needed

If problem persists, contact our customer service department with the model number and serial number of unit for free factory technical assistance at 800-743-7431.

### Adjusting the Differential

Model 2-A and 2-AM controllers have a user adjustable differential, or dead band, around the set point to prevent relay chatter. The potentiometer is mounted on the control card (see page 5). Remove the four panel screws to access. This is a multi-turn pot (you may need to turn it several times to change the differential to its maximum range). To see what the unit’s differential range is adjust the calibration pot to slowly bring the reading past the set point until the relay is turned off.

## **VII. Advantage Controls' Product Warranty**

### **Manufacturer's Product Warranty**

Advantage Controls warrants control systems of its manufacture to be free of defects in material or workmanship. Liability under this policy extends for 24 months from date of installation. Liability is limited to repair or replacement of any failed equipment or part proven defective in material or workmanship upon manufacturer's examination. Removal and installation costs are not included under this warranty. Manufacturer's liability shall never exceed the selling price of equipment or part in question.

Advantage disclaims all liability for damage caused by its products by improper installation, maintenance, use or attempts to operate products beyond their intended functionality, intentionally or otherwise, or any unauthorized repair. Advantage is not responsible for damages, injuries or expense incurred through the use of its products.

The above warranty is in lieu of other warranties, either expressed or implied. No agent of ours is authorized to provide any warranty other than the above.

### **30 Day Billing Memo Policy**

Advantage Controls maintains a unique factory exchange program to ensure uninterrupted service with minimum downtime. If your controller malfunctions, call 1-800-743-7431, and provide our technician with Model and Serial Number information. If he is unable to diagnose and solve your problem over the phone, a fully warranted replacement unit will be shipped, usually within 48 hours, on a 30 Day Billing Memo.

This service requires a purchase order and the replacement unit will be billed at current list price for that model less any applicable resale discount. Upon return of your old unit, credit will be issued to your account if the unit is in warranty. If the unit is out of warranty or the damage not covered, a partial credit will be applied based upon a prorated replacement price schedule dependent on the age of the unit. Any exchange covers only the controller or pump. Electrodes, liquid ends and other external accessories are not included.

# Get the Advantage in Water Treatment Equipment

Advantage Controls can give you the *Advantage* in products, knowledge and support on all of your water treatment equipment needs.

- Cooling Tower Controllers
- Boiler Blow Down Controllers
- Blow Down Valve Packages
- Solenoid Valves
- Water Meters
- Chemical Metering Pumps
- Corrosion Coupon Racks
- Chemical Solution Tanks
- Solid Feed Systems
- Feed Timers
- Filter Equipment
- Glycol Feed Systems

