

# **PulsaPro<sup>®</sup> 900**

Process & Diaphragm Metering Pump

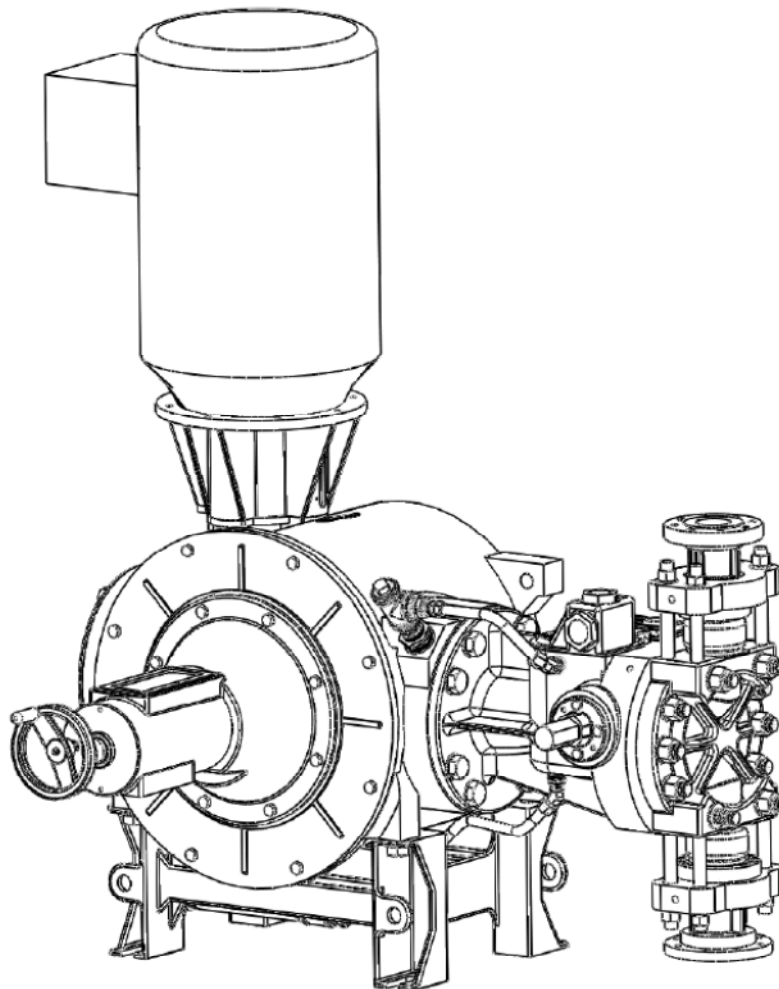

**BULLETIN No.: PulsaPro 900-IOM-2009 Rev. J  
PulsaPro Control Addendum**

**INSTALLATION  
OPERATION  
MAINTENANCE  
INSTRUCTIONS**

---

** PULSAFEEDER**  
A Unit of IDEX Corporation

*Manufacturers of Quality Pumps,  
Controls and Systems*

Pulsafeeder, Inc.  
2883 Brighton Henrietta Town Line Road  
Rochester, New York, 14623  
Email: [pulsa@idexcorp.com](mailto:pulsa@idexcorp.com)  
Telephone: ++1 (585) 292-8000  
Fax: ++1 (585) 424-5619  
[pulsafeeder.com](http://pulsafeeder.com)

## PulsaPro Series Guarantee

Should you experience a problem with your Pulsafeeder pump, first consult the troubleshooting guide in your operation and maintenance manual. If the problem cannot be solved, please contact your local Pulsafeeder Sales Representative, or our Technical Services Department for further assistance.

Trained technicians are available to diagnose your problem and arrange a solution. Solutions may include purchase of replacement parts or returning the unit to the factory for inspection and repair. All returns require a Return Authorization number to be issued by Pulsafeeder. Parts purchased to correct a warranty issue may be credited after an examination of original parts by Pulsafeeder. Warranty parts returned as defective which test good will be sent back freight collect. No credit will be issued on any replacement electronic parts.

Any modifications or out-of-warranty repairs will be subject to bench fees and costs associated with replacement parts.

In addition, Pulsafeeder guarantees its *PulsaPro* Series drive assemblies for a period of five years from the date of shipment. All other material and workmanship are fully covered for a period of one year. Any parts found to be defective within the above time span will be replaced free of charge, F.O.B. our factory.

Equipment or accessories manufactured by others but purchased through Pulsafeeder, such as electric motors, are guaranteed only to the extent of the original manufacturer.

Damages incurred from misuse, abuse, and/or improper protection during storage will be cause to void this guarantee. Erosion, corrosion, or improper application of the equipment or related piping by the buyer or any third party is also excluded.

The above guarantee is in lieu of any other guarantee, either expressed or implied. We make no warranty of fitness or merchantability. No agent of ours is authorized to make any warranty other than the above.

## Safety Considerations:

1. Read and understand all related instructions and documentation before attempting to install or maintain this equipment
2. Observe all special instructions, notes, and cautions.
3. Act with care and exercise good common sense and judgment during all installation, adjustment, and maintenance procedures.
4. Ensure that all safety and work procedures and standards that are applicable to your company and facility are followed during the installation, maintenance, and operation of this equipment.

Copyright ©2009 Pulsafeeder, Inc. All rights reserved.

Information in this document is subject to change without notice. No part of this publication may be reproduced, stored in a retrieval system or transmitted in any form or any means electronic or mechanical, including photocopying and recording for any purpose other than the purchaser's personal use without the written permission of Pulsafeeder, Inc.

# Table of Contents

1. INTRODUCTION .....	1
1.1 General Description .....	1
2. PRINCIPLES OF OPERATION.....	1
2.1 Overall Operation .....	1
2.2 Component Location.....	2
2.2.1 Reagent Head Assembly.....	3
2.2.2 Pump Head/Piston Assembly.....	4
2.2.3 Control Assembly .....	6
2.2.4 Gear Reducer Assembly .....	7
3. EQUIPMENT INSPECTION .....	8
4. STORAGE INSTRUCTIONS .....	8
4.1 Short Term .....	8
4.2 Long Term .....	8
5. INSTALLATION .....	9
5.1 Location.....	9
5.2 Mounting .....	9
5.3 Piping System.....	10
5.3.1 Suction Pressure Requirements .....	11
5.3.2 Discharge Pressure Requirements.....	11
6. EQUIPMENT STARTUP .....	12
6.1 Lubrication .....	12
6.1.1 Oil Capacities .....	12
6.1.2 Oil Fill.....	14
6.1.3 Oil Changes.....	16
6.2 Startup .....	17
6.2.1 Output Adjustment .....	17
6.2.2 Priming the Pump Head .....	18
6.2.3 Priming the Reagent Head .....	18
6.2.4 Motor Rotation .....	19
6.2.5 Calibration .....	20
7. MAINTENANCE .....	21
7.1 Wet End Removal, Inspection, and Reinstallation .....	22
7.2 Re-Priming the Pump Head .....	24
7.2.1 Re-Filling the Hydraulic System.....	25
7.2.2 Re-Priming the Hydraulic System.....	25
7.3 Check Valves .....	26
7.3.1 Check Valve Removal .....	27
7.3.2 Ball Valve – Inspection and Repair .....	27
7.3.3 Disk Valve – Inspection and Repair .....	27
7.3.4 Check Valve Reinstallation.....	28
7.4 Hydraulic Performance Valve (HPV).....	29
7.4.1 HPV Removal and Replacement .....	30
7.5 Hydraulic Bypass Valve (HBV).....	31
7.5.1 PTP (Push To Purge) Valve .....	32
7.5.2 PTP Removal, Cleaning, and Reinstallation .....	33
7.5.3 Piston Seal .....	34
7.5.4 Piston Removal.....	35
7.5.5 Piston Seal Reinstallation.....	35
7.6 Oil Seals .....	37
7.6.1 General Description.....	37
7.6.2 Motor Adaptor Oil Seal Removal and Replacement.....	38
7.7 Stroke Control Assembly .....	40
7.7.1 Stroke Control Assembly Maintenance.....	40
7.8 Motor Removal and Reinstallation .....	41
8. REPLACEMENT PARTS .....	42
8.1 PulsaPro Series KOPkit Program .....	42

8.2	Ordering KOPkits or Parts.....	42
9.	PULSALARM LEAK DETECTION PUMP HEAD ASSEMBLY .....	43
9.1	PULSAlarm Leak Detection Diaphragm .....	44
9.2	Leak Detection – Setup for Pressure.....	44
9.3	Pressure System Set-up and Priming .....	45
9.4	PULSAlarm Leak Detection Diaphragm Maintenance .....	47
9.4.1	Leak Detection Diaphragm Removal .....	48
9.4.2	Inspection.....	48
9.4.3	Leak Detection Diaphragm Reinstallation .....	48
10.	TROUBLESHOOTING CHART.....	49
	APPENDIX I – PIPING CALCULATIONS .....	51
	Suction Head Requirements .....	51
	System Back Pressure.....	53
	Nomenclature.....	53
	APPENDIX II – OIL SPECIFICATIONS.....	54
	<i>PULSAlube</i> Universal 1HG .....	54
	APPENDIX III – BOLT TORQUE RECOMMENDATIONS/NOZZLE LOADS .....	55
	Reagent Head and Tie-Bar.....	55
	Pump Head Bolts.....	55
	Nozzle Loads.....	56
	APPENDIX IV DIMENSIONAL DRAWINGS.....	57
	APPENDIX V EC DECLARATION OF CONFORMANCE .....	62
	PULSA PRO CONTROL ADDENDUM.....	63

## Conventions

For the remainder of this bulletin, the following Conventions are in effect.



**A WARNING DEFINES A CONDITION THAT COULD CAUSE DAMAGE TO BOTH THE EQUIPMENT AND THE PERSONNEL OPERATING IT. PAY CLOSE ATTENTION TO ANY WARNING.**



Notes are general information meant to make operating the equipment easier.



Tips have been included within this bulletin to help the operator run the equipment in the most efficient manner possible. These “Tips” are drawn from the knowledge and experience of our staff engineers, and input from the field.

# 1. Introduction

## 1.1 General Description

Diaphragm Metering pumps are positive displacement reciprocating pumps that combine the high efficiency of the plunger pump with a sealed diaphragm that prevents product leakage. Each pump consists of a power end and a process end separated by a hydraulically operated diaphragm. Individual pumps will vary in appearance due to various liquid ends, accessories, and multiplexing - however, the basic principles of operation remain the same.

## 2. Principles of Operation

### 2.1 Overall Operation

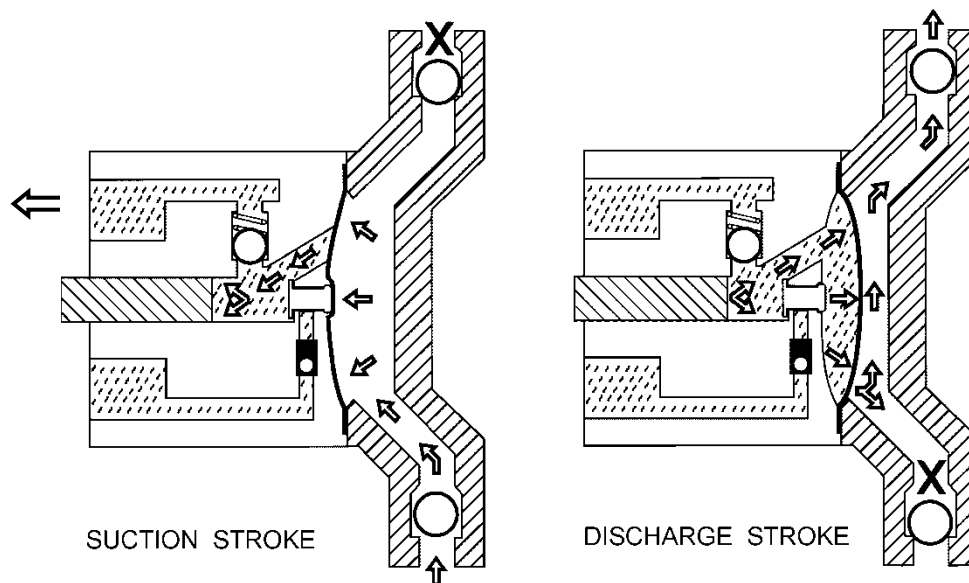

Figure 1

A piston reciprocates within an accurately sized cylinder at a preset stroke length, displacing an exact volume of hydraulic fluid. The hydraulic fluid acts against a sealed diaphragm, which pumps the chemicals.

The piston and associated mechanisms are enclosed by a chamber called the Pump Head or intermediate housing. This also acts as a hydraulic oil reservoir.

The diaphragm separates the hydraulic oil from the product pumped. The diaphragm moves in exact response to the piston displacement. The diaphragm does no work, and acts only as a separator.

The displacement of the oil is translated into an equal displacement of the chemical being pumped. Therefore, piston retraction causes the product to enter through the suction check valve. Piston advance causes the discharge of an equal amount of the product through the discharge check valve.

## 2.2 Component Location

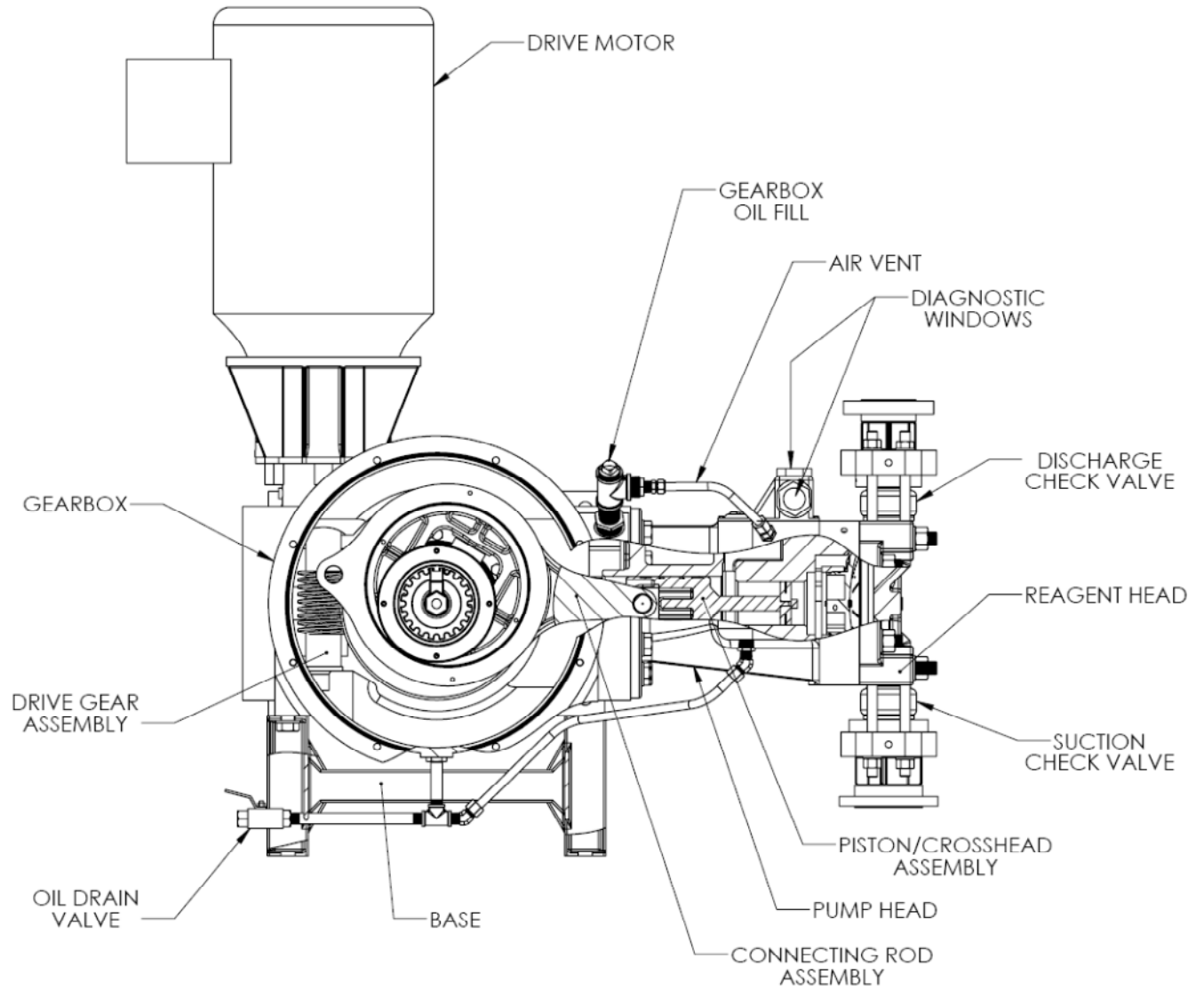

Figure 2

## 2.2.1 Reagent Head Assembly

The term Reagent Head Assembly refers to the pump components that come into direct contact with the process fluid (or Reagent). The typical Reagent Head Assembly consists of the following components:

- a) Reagent Head
- b) Diaphragm
- c) Suction Check Valve
- d) Discharge Check Valve



**High flow pump models use disk valves.**

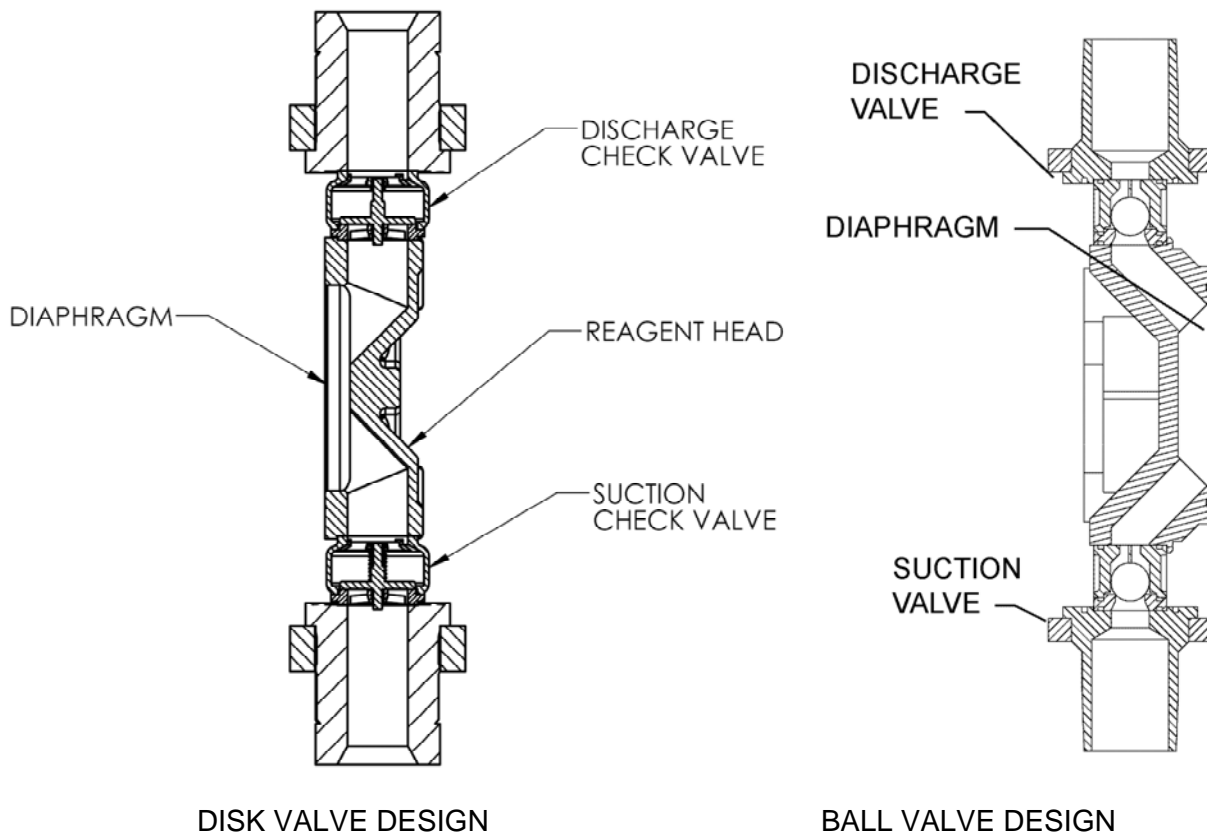

*Figure 3*

## 2.2.2 Pump Head/Piston Assembly

The pump head/piston assembly is installed on the intermediate housing. This assembly contains the hydraulic system which consists of the pump head, cylinder, piston assembly, and four hydraulic valves:

- a) Push-To-Purge (PTP)
- b) Hydraulic Performance Valve (HPV)
- c) Hydraulic Makeup Valve (HMV)
- d) Hydraulic Bypass Valve (HBV)

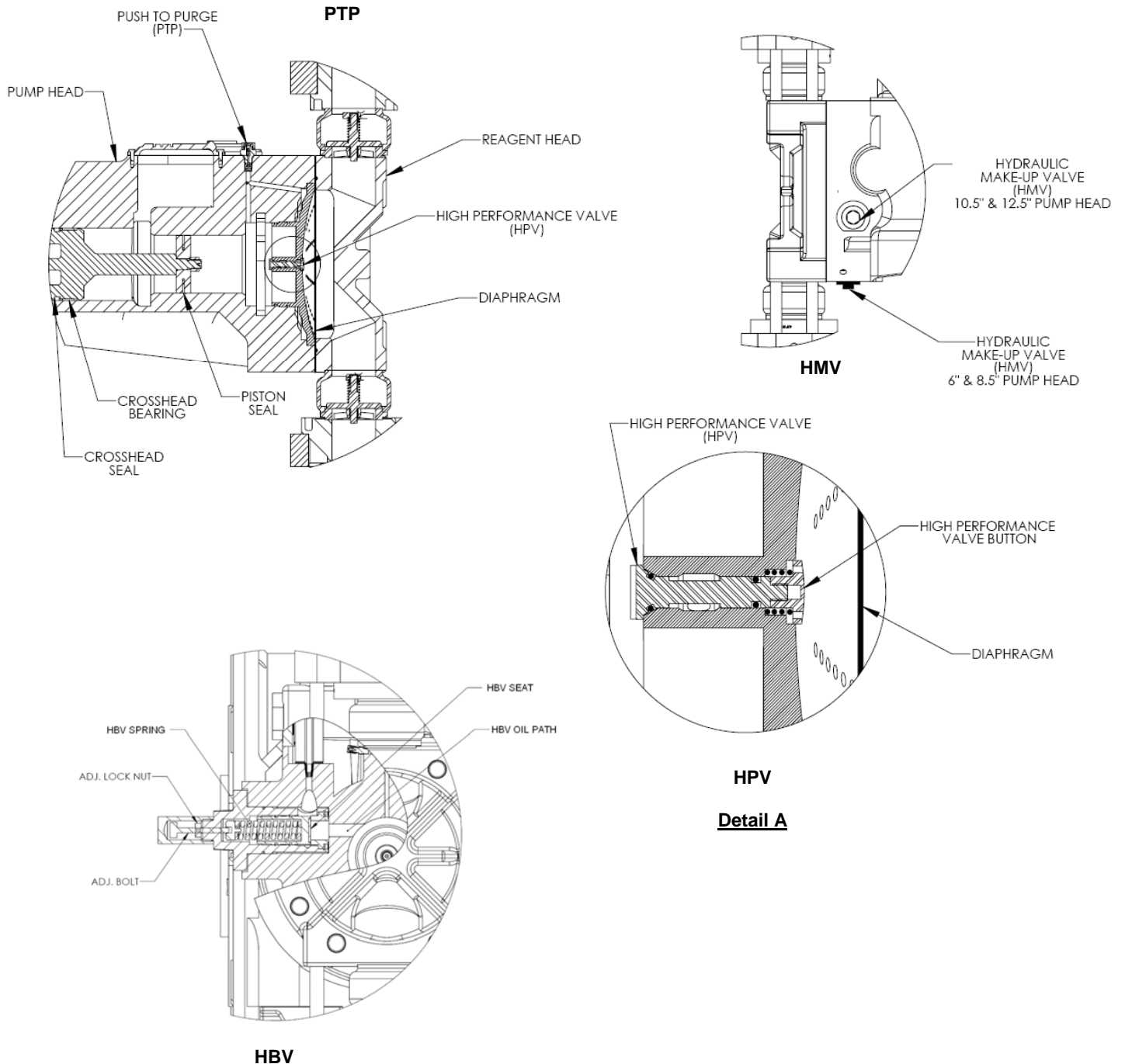

Figure 4



### **2.2.2.1 Push to Purge (PTP)**

The Push to Purge (PTP) valve is located at the top of the Pump Head. It automatically removes air entrained in the hydraulic system. Pressing down on the button at the top of the PTP overrides its automatic operation. This allows a small amount of hydraulic fluid to bleed from the pump head to the reservoir every stroke. Activating the PTP in this manner helps determine if the pump head is properly primed and diaphragm integrity is maintained.

### **2.2.2.2 Hydraulic Performance Valve (HPV)**

The Hydraulic Performance Valve (HPV) automatically maintains the hydraulic oil that “connects” the piston to the diaphragm. During normal operation small amounts of hydraulic fluid is lost past the piston seal and PTP. This causes the diaphragm to move progressively closer to the button on the HPV valve (see Figure 4, Detail A). Over time, the diaphragm will come into contact with this button. When this occurs, it will push the HPV valve open allowing lost hydraulic fluid to be replenished.

### **2.2.2.3 Hydraulic Makeup Valve (HMV)**

The Hydraulic Makeup Valve (HMV) works in conjunction with the HPV to assure hydraulic oil flows in one direction (into the diaphragm/piston chamber) at the correct pressure.

### **2.2.2.4 Hydraulic Bypass Valve (HBV)**

The Hydraulic Bypass Valve (HBV) protects the pump from over-pressurizing by relieving any excess pressure. It is typically set at 110% of the Pump’s discharge pressure.

## 2.2.3 Control Assembly

The output of the *PulsaPro 900* can be controlled by changing how far the piston moves with each pump stroke. The Piston is attached to a rotating cam with a connecting rod. The Control Assembly allows the throw of the cam to be adjusted (see **Figure 5**). The assembly consists of the following parts:

- e) Hand wheel
- f) Threaded Shaft
- g) Inner Stroke Adjust Shaft
- h) Large and Small Plunger
- i) Inner Cam

### 2.2.3.1 Operation

The output of the pump is varied by turning the Hand Wheel. The Hand Wheel turns a threaded shaft. Depending on the direction of rotation, this either pulls the inner stroke adjustment shaft towards the hand wheel or pushes it away. The inner stroke shaft includes two opposite faces that are machined on an angle. A Large and Small Plunger ride on these opposite faces. An Inner Cam rides over the plungers. As the position of the Inner Stroke Adjustment Shaft changes, the Plungers shift from one side to the other causing the throw of the cam to change.

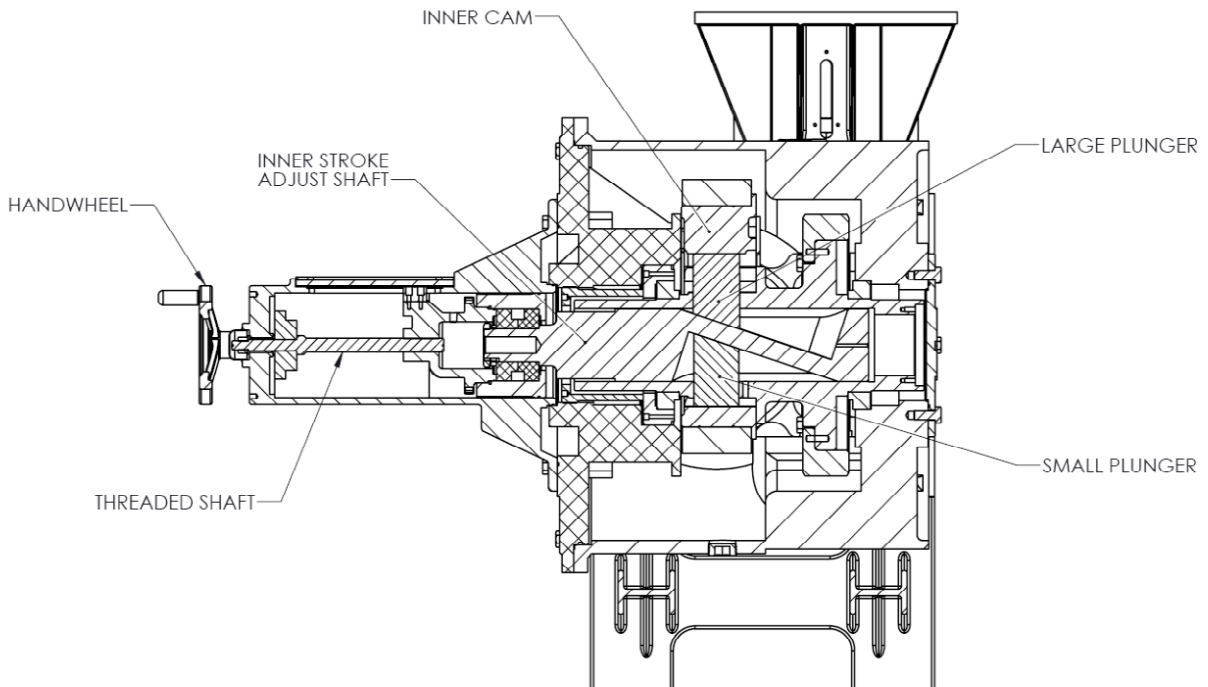
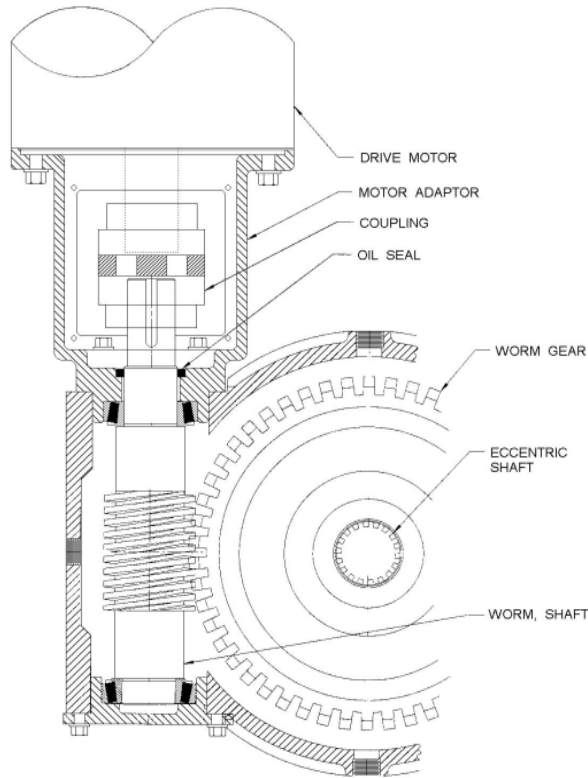

*Figure 5*

The stroke length setting is denoted by a 0 – 100% scale with 2.5% increments. The scale is located on the top part of the stroke control housing under a clear sealed cover.

## 2.2.4 Gear Reducer Assembly

*PulsaPro 900* pumps are driven by a standard C-face electric motor mounted to an adaptor that completely encloses a coupling. The motor drives a worm gear reduction that turns an eccentric shaft assembly – converting the rotary motion into reciprocating motion.



*Figure 6*

A single drive assembly can drive up to four Pump/Reagent Head assemblies. This is referred to as multiplexing.

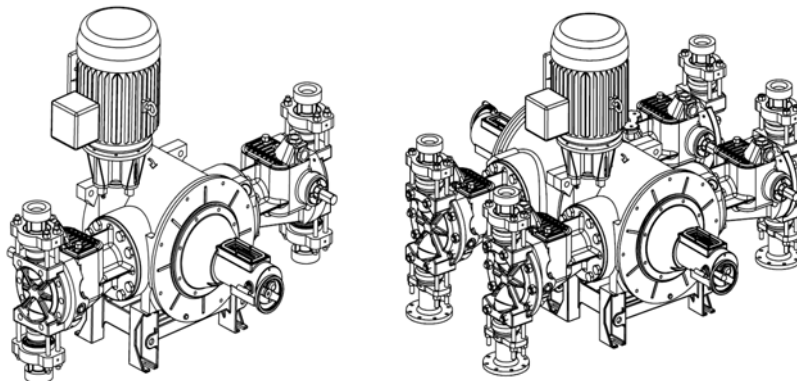

*Figure 7*

Whenever pumps are multiplexed the eccentric shafts are positioned to place a uniform load on the drive. Before full disassembly always note the relative positions of the eccentric shafts to each other so they can be reassembled back in the same orientation.

### 3. Equipment Inspection

Check all equipment for completeness against the order and for any evidence of shipping damage. Shortages or damage should be reported immediately to the carrier and your *PulsaPro* Representative.

### 4. Storage Instructions

#### 4.1 Short Term

Storage of *PulsaPro* Series pumps for up to 12 months is considered short-term. The recommended short-term storage procedures are:

- a) Store the pump indoors at room temperature in a dry environment.
- b) Prior to startup, inspect the pump head, and gearbox. Replenish oil as required to maintain operating levels. If water or condensation is present, change oil as described in the *Equipment Startup* section.
- c) Prior to startup, perform a complete inspection and then start up in accordance with the instructions in this manual.

#### 4.2 Long Term

Every twelve months, in addition to the above short-term procedures, power up the motor and operate the pump for a minimum of one hour. It is not necessary to have liquid in the reagent head during this operation, but the suction and discharge ports must be open to atmosphere.

After twelve months of storage, Pulsafeeder's warranty cannot cover items that are subject to deterioration with age such as seals and gaskets. If the pump has been in storage longer than 12 months it is recommended that all seals and gaskets be inspected and replaced as necessary prior to startup. Materials and labor to replace this class of item under this circumstance are the purchaser's responsibility. For a continuance of the 5 year warranty after extended storage, equipment inspection and any required refurbishing must be done by a Pulsafeeder Representative.

## 5. Installation

### 5.1 Location

When selecting an installation site or designing a skid package, consideration should be given to access for routine maintenance.

*PulsaPro 900* pumps are designed to operate indoors and outdoors. At a minimum, a covering to protect the pump from direct weather and sunlight is required. External heating and/or the use of synthetic lubricants for the gearbox is recommended if ambient temperatures below 20°C (0°F) or above 40°C (104°F) are anticipated. Check with the factory if you are concerned with the suitability of the operating environment.

### 5.2 Mounting

The pump must be rigidly bolted to a solid and flat foundation to minimize vibration, which can loosen connections. Bolt each base with a minimum of 1" diameter studs with flat and lock washers in 4 locations per base (note: the quad configurations include 2 bases). The pump must be level within 2°. This will assure that the oil is maintained at the proper level and that the check valves can operate properly.

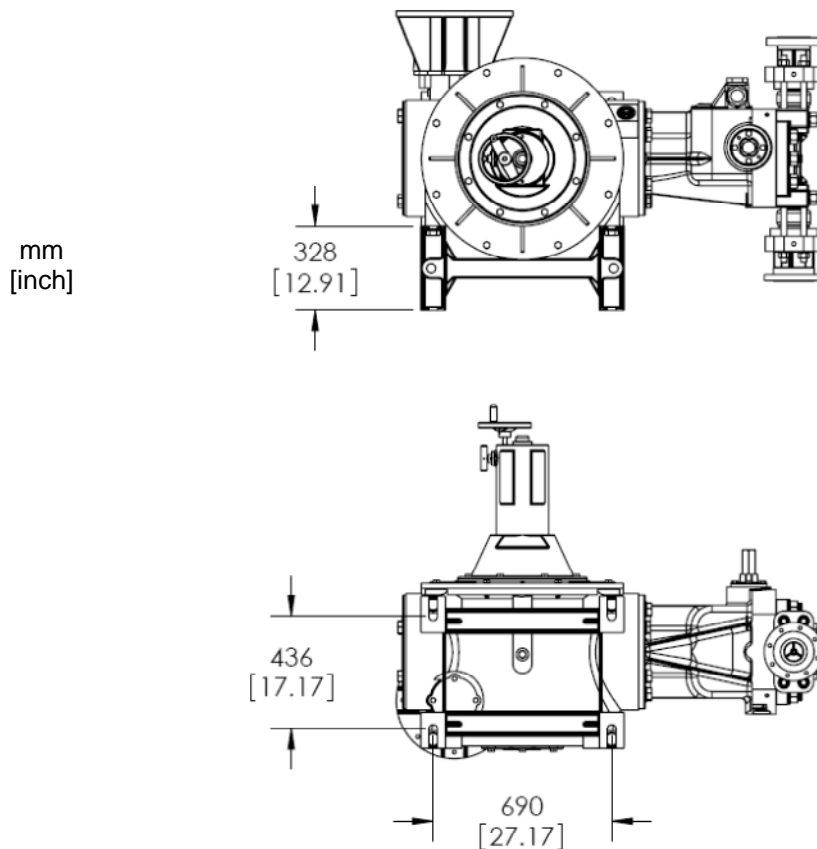

Figure 7

## 5.3 Piping System

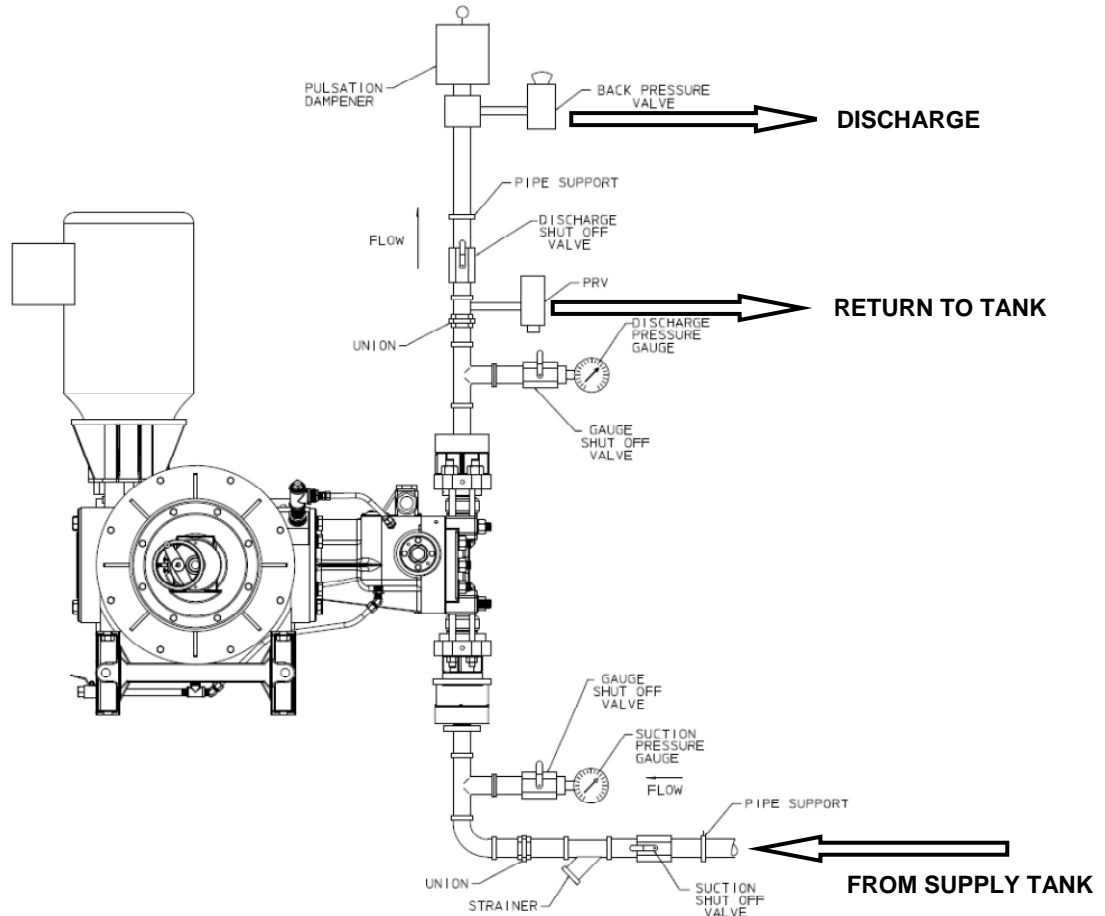

Figure 8A

All piping systems should include:

1. Shutoff valves and unions (or flanges) on suction and discharge piping.
  - a) This permits check valve inspection without draining long runs of piping.
  - b) Shutoff valves should be of the same size as connecting pipe.
  - c) Ball valves are preferred since they offer minimum flow restriction.
2. An inlet strainer, if the process fluid is not a slurry.
  - a) Pump check valves are susceptible to dirt and other solid contaminants unless designed for that service, and any accumulation can cause malfunction.
  - b) The strainer should be located between the suction shutoff valve and the pump suction valve.
  - c) It must be sized to accommodate the flow rate and the anticipated level of contamination.
  - d) 100 mesh screen is recommended.
3. Vacuum/pressure gauges in the suction and discharge lines in order to check system operation.
  - a) Gauges should be fitted with protective shutoff valves for isolation while not in use.

4. A separate system relief valve to protect piping and process equipment, including the pump, from excess process pressures.

- a) The hydraulic bypass valve (HBV) in the pump is not intended to protect the system.

Piping weight must not be supported by valve housings or other portions of the reagent head, as the resulting stresses can cause leaks. If appropriate, provide for thermal expansion and contraction so that no excess force or movement is applied to the pump.

In piping assembly, use a sealing compound chemically compatible with the process material. Users of sealing tape are cautioned to ensure that the entering pipe thread ends are not taped, and that tape is removed from previously-used threads prior to re-use. Both new and existing piping should be cleaned, preferably by flushing with a clean liquid (compatible with process material) and blown out with air, prior to connection to the pump.

### 5.3.1 Suction Pressure Requirements

Although metering pumps have suction lift capability, all pump installations should be designed to minimize lift for optimal performance. A flooded suction (i.e., suction fluid level higher than the centerline of the pump) is preferable whenever possible. The pump should be located as close as possible to the suction side reservoir or other source.

If suction lift is required, the minimum net positive suction pressure required (NPSH<sub>R</sub>) is **3 psia (0.21 bar)** above the Vapor Pressure of the Process Fluid. If this requirement is not met the Process Fluid may cavitate inside the pump, degrading metering accuracy.

Likewise, if the suction pressure is low enough, it is possible to cavitate the hydraulic fluid used to move the diaphragm in the pump. Therefore, suction pressure must also be maintained at a minimum absolute value of **5 psia (0.34 bar)** to ensure proper hydraulic system and pump operation.

The suction pressure must not exceed **165 psia (11.38 bar)** for pumps with TFE diaphragms. Please consult the factory for higher suction applications.



**Higher pressures may be possible with optional alternate diaphragm materials or modified dish plates.**

Refer to *Appendix I* for a complete explanation of Suction Pressure Requirements including methods to calculate values for your system.

### 5.3.2 Discharge Pressure Requirements

All Pulsafeeder Metering Pumps are designed for continuous service at the rated discharge pressure. If system suction pressure were to exceed system discharge pressure (a condition sometimes described as “pumping downhill” or “flow-through”), excess flow would be generated, resulting in a reduction in accuracy and loss of control over the metering process. To prevent this condition, the discharge pressure must exceed the suction pressure by at least **25 psia (1.7 bar)**. This can be achieved where necessary by installing a backpressure valve in the discharge line.



**DISCHARGE PRESSURE MUST NEVER EXCEED THE HYDRAULIC BYPASS VALVE (HBV) SETTING ON THE NAMEPLATE. EXCESSIVE DISCHARGE PRESSURE COULD IMPAIR PERFORMANCE, DAMAGE THE PUMP AND VOID THE WARRANTY.**

Refer to *Appendix I* for a complete explanation of Discharge Pressure Requirements including methods to calculate values for your system.

## 6. Equipment Startup

### 6.1 Lubrication



**PULSAPro 900 PUMPS USE *PULSALUBE UNIVERSAL 1HG* OIL AS STANDARD FOR THE PUMP HEAD AND GEARBOX. USE OF ALTERNATIVE LUBRICANTS COULD IMPAIR PERFORMANCE, DAMAGE THE PUMP AND VOID THE WARRANTY.**

#### 6.1.1 Oil Capacities

The approximate amounts of oil required to fill the *PulsaPro 900* to the specified level is:

<b><i>Pulsalube Universal 1HG</i></b> is standard oil supplied with all pumps unless specified. Temperatures +40 – 280 °F		
Total - Pump Head and Gear Box	25	Gallons
	94.6	Liters

***PULSAlube Universal 1HG*** is available as follows:

- 1 quart (0.94 liters) Part #: 1HG-1QT
- 1 gallon (3.79 liters) Part #: 1HG-1GL
- 5 gallons (18.9 liters) Part #: 1HG-5GL
- 55 gallons (208.2 liters) Part #: 1HG-55GL

It is recommended that adequate supplies of ***Pulsalube Universal 1HG*** be on hand for periodic changes and emergency requirements.

Pulsafeeder also offers oil options for extreme operating conditions.

<b><i>Pulsalube Ultra 6HGS</i></b> is Non-standard oil and is for special applications Temperatures -40 – 400 °F		
Total - Pump Head and Gear Box	25	Gallons
	94.6	Liters

***PULSAlube Ultra 6HGS*** is available as follows:

- 1 gallon (3.79 liters) Part #: 6HGS-1GL
- 5 gallons (18.9 liters) Part #: 6HGS-5GL
- 55 gallons (208.2 liters) Part #: 6HGS-55G





## 6.1.2 Oil Fill

The pump is shipped from the factory filled to the proper level with **PULSA**lube **Universal or Ultra**. The oil is held within two main reservoirs – the Gear Box (located on the motor end of the pump) and the Pump Head (located on the process fluid end of the pump). The two reservoirs are connected to allow lubricant to flow between them to assure a constant oil level across the entire pump.

Two sight glasses provide a visual confirmation of oil level. One is located in the Pump Head next to the HBV valve. The second is located in the Gearbox below the motor on the centerline. The construction and operating conditions of the pump can cause the oil level to go up or down during operation – this is normal. The level should be set to the center of the sight glass. During operation the level can increase or decrease from this position, but should always be visible within the window. For reliable measurements shut the pump off, set the Stroke Adjustment to 0% stroke and wait approximately 5 minutes before reading the sight glass levels.

The oil fill is located on the top of the gearbox opposite the motor (see Figure 9A). To fill, remove the cover and add **PULSA**lube **Universal or Ultra**. Because this one fill location supplies two reservoirs, it is necessary to wait several minutes for the level to stabilize across the entire pump.



WARNING

**DO NOT OVERFILL! OVERFILLING CAN CAUSE MALFUCTION AND MAY RESULT IN DAMAGE NOT COVERED BY WARRANTY.**



NOTE

**During normal operation, the worm gear running behind the sight glass in the gearbox will cause oil to cover the glass completely. This is normal and does not reflect the true measure of oil level. Turn the pump off and set the Stroke Adjustment to 0% to check the oil level properly.**

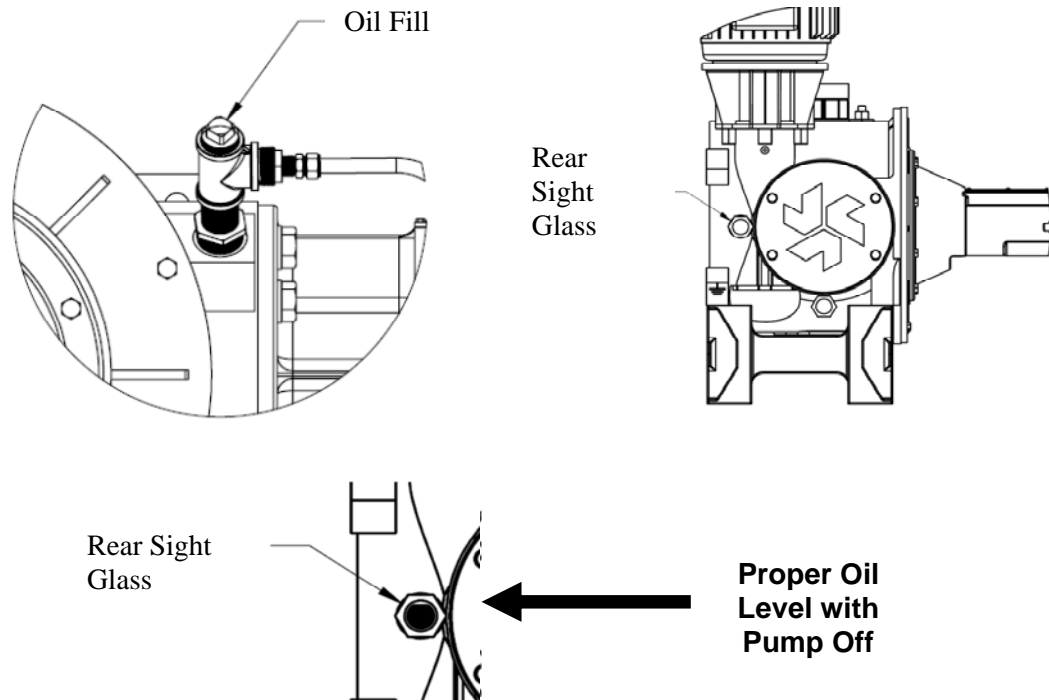
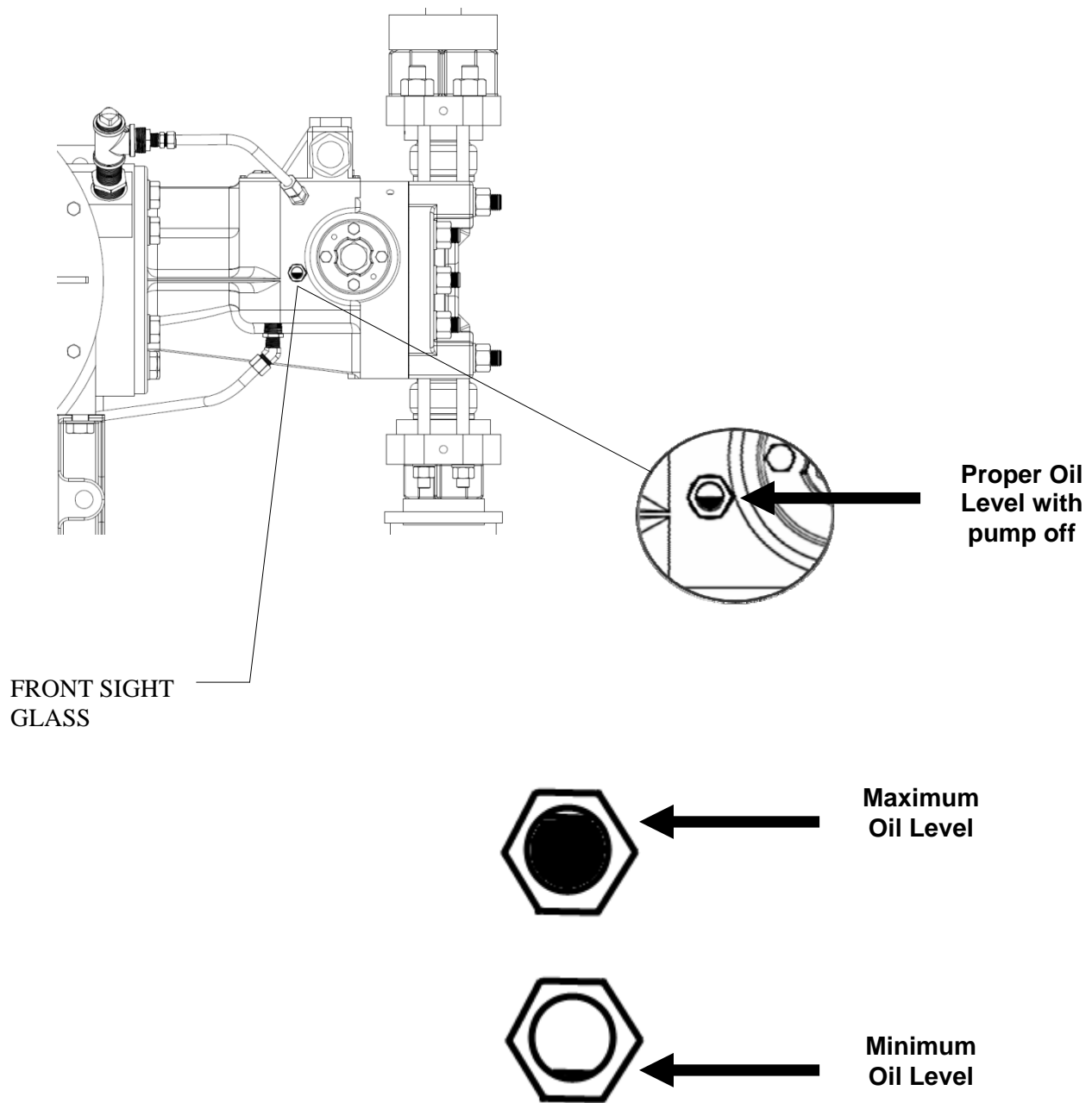

Figure 9A: Gearbox Oil Level



*Figure 9B: Pump Head Oil Level – Maximum/Minimum Definition*

## 6.1.3 Oil Changes

### 6.1.3.1 Service Level Definition

The recommended oil change intervals are dependent upon the operating environment and level of pump usage, classified as follows:

#### Normal service

Clean/dry atmosphere, an ambient operating temperature of 0°C to 40°C (32°F to 104°F), and up to 2,000 annual operating hours.

#### Severe Service

Humid atmosphere, an ambient operating temperature below 0°C (32°F) or above 40°C (104°F), and over 2,000 annual operating hours.

### 6.1.3.2 Oil Change:

The recommended oil change interval is 2 years for normal service and 1 year for severe service. The first oil change should be done after six (6) months of continuous operation (approximately 1,000 hours). The procedure is as follows:

1. Disconnect the power source to the drive motor (e.g., lockout/tagout the motor disconnect).
2. Relieve all pressure from the piping system.
3. Set the Stroke Adjustment to 0% Stroke.
4. Remove the oil fill cap.
5. Drain the oil by opening the Oil Drain Valve at back of the Gearbox underneath the base.
6. Close the Oil Drain Valve.
7. Fill the Pump with 20 Gallons (75 Liters) of **PULSAlube Universal or Ultra**.
8. Wait for 10 minutes for the oil to level across the pump.
9. Slowly add more **PULSAlube Universal or Ultra** until the oil level centers on the gearbox sight glass and the pump head sight glass.

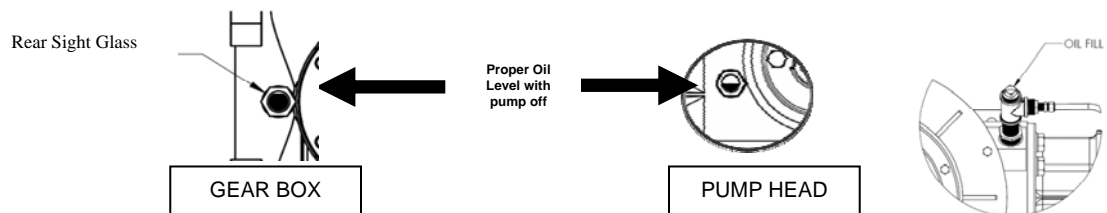

10. Replace the Oil Fill Cap.
11. Set the Stroke Adjustment to the proper setting.
12. Remove Motor Starter Lockout/Tagout.

## 6.2 Startup

### 6.2.1 Output Adjustment



When starting up the pump for the first time, it is best to set the stroke adjustment to 0% output and then slowly increase the setting to 100%. This allows you to react to any leaks that may be present in the piping system before they become severe.

The *PulsaPro 900* uses a hand wheel for manual stroke adjustment. It is mounted on the rear of the stroke adjust housing (refer to Figure 10). The hand wheel can be adjusted at any point from 0 to 100%. It includes a stroke lock mechanism. Before making an adjustment pull out the stroke lock handle and rotate it ¼ turn to hold it in the disengaged position. With the stroke lock disengaged, crank the hand wheel in either direction to adjust the stroke length to the desired setting – do not go below the 0% or above the 100% marks. After you have completed your stroke length setting, re-engage the stroke lock by turning the stroke lock handle ¼ turn.



Please be sure the stroke lock is then engaged during pump operation to prevent drift.

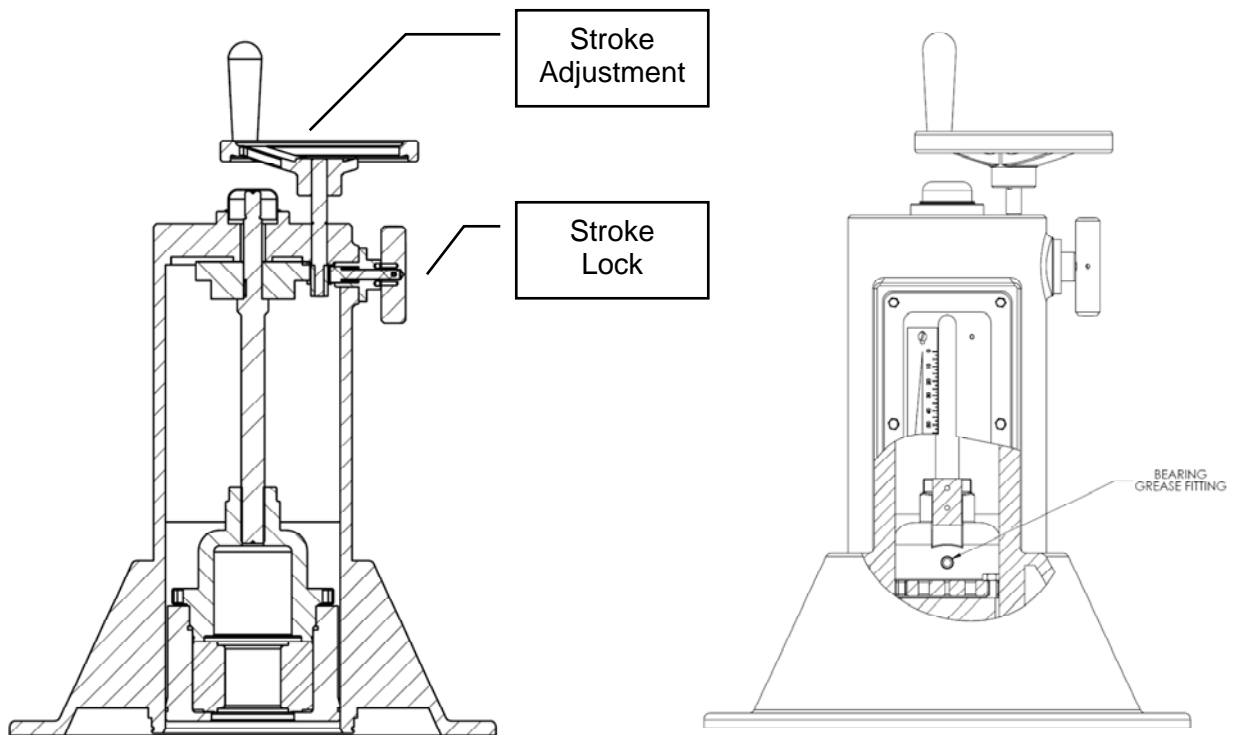
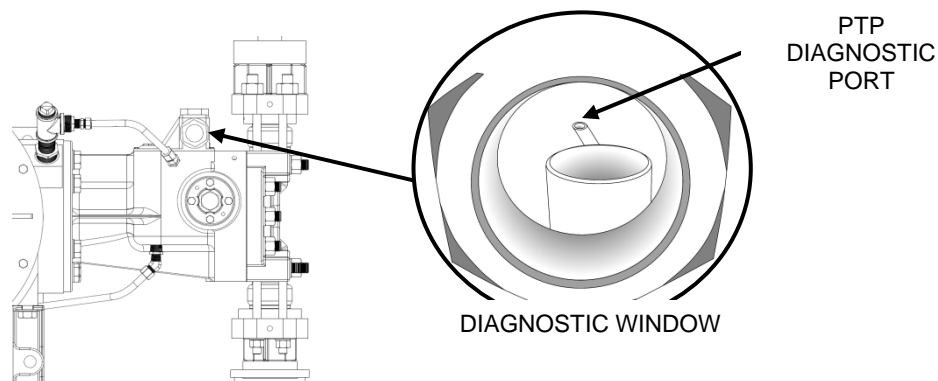

Figure 10

## 6.2.2 Priming the Pump Head

All pumps are shipped with a fully primed hydraulic system. However, during shipping, handling and storage some air may accumulate in the hydraulic system resulting in reduced performance. Generally this air will be automatically purged after a short run-in period. If necessary, rapid purging may be accomplished by:

1. Fully depressing and holding the button on top of the PTP valve while the pump is operating at any stroke length setting above 30%.
2. With the PTP button depressed, oil should begin to flow out of the small diagnostic port.



3. Hold the valve down for several seconds after the oil is clear of bubbles to ensure a good prime.

If the pump fails to prime refer to *Section 7.2.1, Re-Priming the Pump Head*.

## 6.2.3 Priming the Reagent Head

To prime the Reagent Head with the process fluid:

1. Open the suction and discharge line shutoff valves.
2. If the piping system design and the storage tank are such that the product flows due to gravity through the pump, no priming is required.  
In the event the discharge line contains a significant amount of pressurized air or other gas, it may be necessary to lower the discharge pressure to enable the pump to self-prime.
3. If the installation involves a suction lift, it may be necessary to prime the reagent head and suction line. Try priming the reagent head first.
  - a) Remove the discharge valve by unscrewing the four tie bar bolts and removing the valve as a unit.
  - b) Fill the head through the discharge valve port with process (or compatible) liquid
  - c) Reinstall the valve and retighten the tie bar bolts.
4. Start the pump at the 100% stroke length setting to prime the pump. If this does not work, it will be necessary to fill the suction line.  
Filling of the suction line will necessitate the use of a foot valve or similar device at the end of the suction line so that liquid can be maintained above the reservoir level.
  - a) Remove the suction valve assembly.
  - b) Fill the line
  - c) Replace the valve.
  - d) Remove the discharge valve assembly and fill the reagent head as described in Step 3 above.

## 6.2.4 Motor Rotation

Verifying the proper rotation of the motor

- a) To verify the correct shaft rotation of the motor you can remove the 3 screws to the access cover or remove the large pipe plug on the side of the motor adaptor housing. This will allow you visual sight of the motor coupling to verify rotation.
- b) Another way to verify the proper motor rotation is to observe the rotation of the fan on the motor.



Observing from the rear of the pump the Proper rotation of the input shaft of the Pro 900 pump is ***CLOCKWISE***. Please also refer to the arrow that is cast into the gearbox for proper rotation.

## 6.2.5 Calibration

All metering pumps must be calibrated to accurately specify stroke length settings to achieve required flow rates.

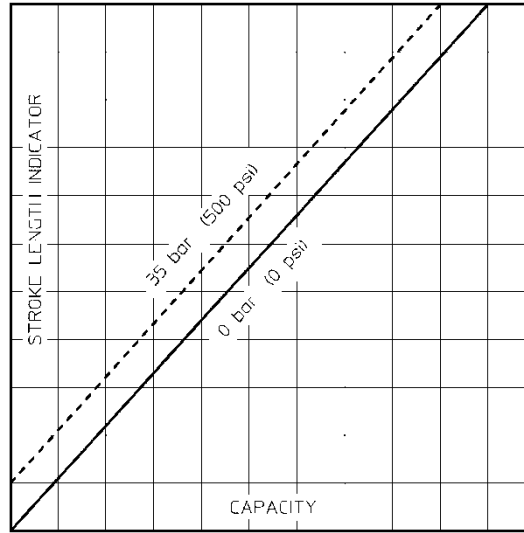

Figure 11

A typical calibration chart is shown in **Figure 11**. Although output is linear with respect to stroke length setting, an increase in discharge pressure decreases output uniformly, describing a series of parallel lines, one for each pressure (only two are shown in the figure).

The theoretical output flow rate at atmospheric pressure is based on the displacement of the hydraulic piston (the product of the piston cross-sectional area and stroke length) and the stroking rate of the pump.

Whenever possible, calibration should be performed under actual process conditions (i.e., the same or a similar process liquid at system operating pressure).

To assure a sound hydraulic system, run the pump for 15-20 minutes prior to calibration. This will allow the PTP (automatic bleed) valve to purge any air from the system.



**Allowing the pump to run for several hours prior to performing a calibration will provide better results.**

TIP

Procedure for constructing a calibration chart,

1. Measure the flow rate several times at three or more stroke settings (e.g., 25, 50, 75, and 100%).
2. Plot these values on linear graph paper.
3. Draw a best-fit line through the points.

For stable conditions, this line should predict stroke settings to attain required outputs.



## 7. Maintenance



**ALWAYS LOCKOUT/TAGOUT THE PUMP MOTOR BEFORE PERFORMING MAINTENANCE OF ANY KIND.**



**BEFORE PERFORMING ANY MAINTENANCE REQUIRING REAGENT HEAD OR VALVE (WET END) DISASSEMBLY, BE SURE TO RELIEVE PRESSURE FROM THE PIPING SYSTEM.**



**WHERE HAZARDOUS PROCESS MATERIALS ARE INVOLVED, RENDER THE PUMP SAFE TO PERSONNEL AND THE ENVIRONMENT BY CLEANING AND CHEMICALLY NEUTRALIZING AS APPROPRIATE. WEAR ALL REQUIRED PROTECTIVE CLOTHING AND USE PROTECTIVE EQUIPMENT.**

Accurate records from the early stages of pump operation will indicate the type and levels of required maintenance. A preventative maintenance program based on such records will minimize operational problems. It is not possible to forecast the lives of wetted parts such as diaphragms and check valves. Since corrosion rates and operational conditions affect functional material life, each metering pump must be considered according to its particular service conditions.

*PulsaPro* Series **KOPkits** contain all replacement parts normally used in a preventative maintenance program. It is recommended that **KOPkits** and **PULSAlube** oil be kept available at all times.

Each *PulsaPro* Series pump is provided with an individual specification data sheet included with the documentation package. The data sheet contains important information relating to the application along with pump serial number, pump specifications (i.e., materials, piston size, stroking rate, etc.).

## 7.1 Wet End Removal, Inspection, and Reinstallation



**IF THE DIAPHRAGM HAS FAILED, PROCESS FLUID MAY HAVE CONTAMINATED THE PUMP OIL. HANDLE WITH APPROPRIATE CARE, CLEAN AND REPLACE OIL IF REQUIRED.**



**DUE TO THE SIZE AND WEIGHT OF WET END COMPONENTS, CARE MUST BE USED TO SELECT THE PROPER TOOLS AND LIFTING EQUIPMENT FOR HEAVY LOADS.**

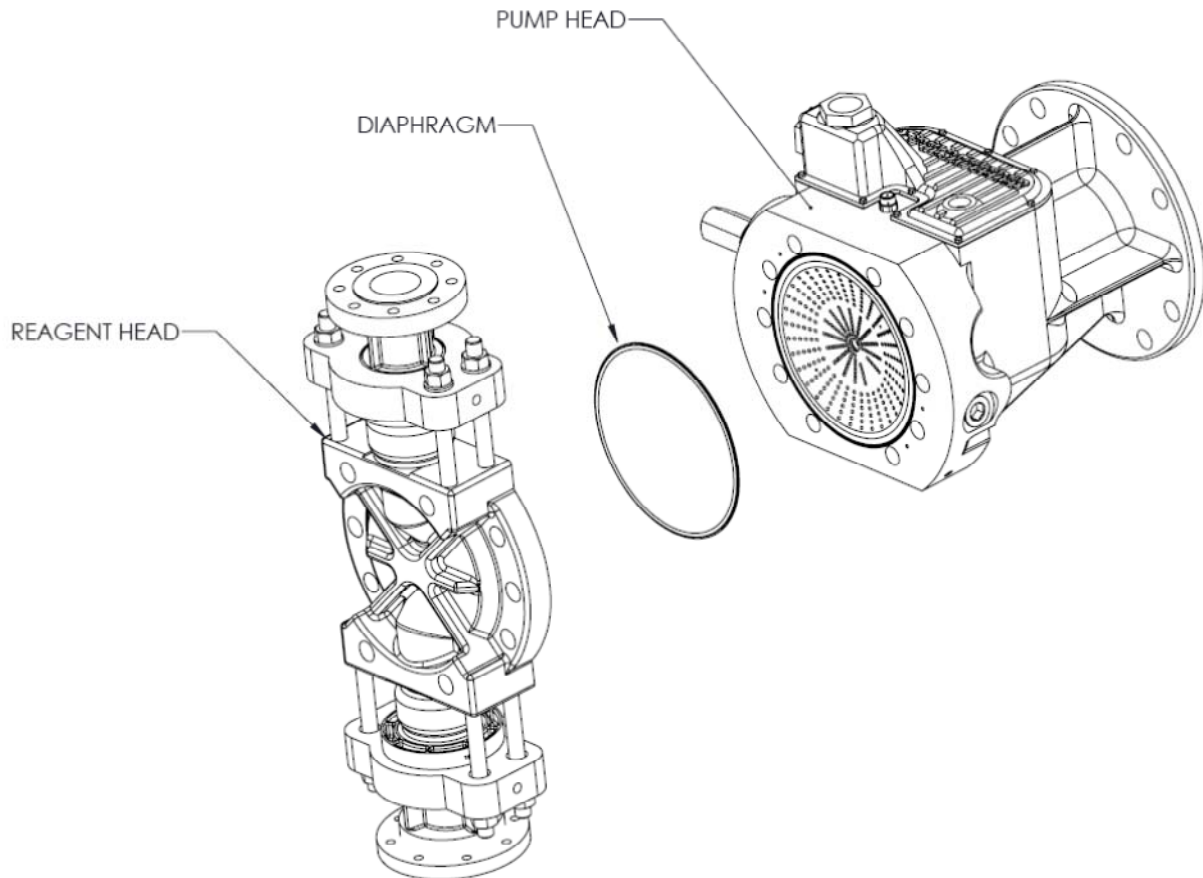

*Figure 12*

*PulsaPro* Series diaphragms do not have a specific cycle life. However, the accumulation of foreign material or the entrapment of sharp particles between the diaphragm and dish cavity can eventually cause failure. Failure can also occur as a result of hydraulic system malfunction or chemical attack. Periodic diaphragm inspection and replacement is recommended.



**TAKE ALL PRECAUTIONS TO PREVENT ENVIRONMENTAL AND PERSONNEL EXPOSURE TO HAZARDOUS MATERIALS.**

## Diaphragm Replacement procedure

1. Disconnect the power source to the drive motor (e.g., lockout/tagout the motor disconnect).
2. Relieve all pressure from the piping system.
3. Close the suction and discharge shutoff valves (refer to *Figure 8A*).
4. Disconnect piping to the reagent head and drain any process liquid, following material safety precautions from the process liquid manufacturer.
5. Place a pan underneath the pump head to catch any oil leakage from the pump.
6. If the oil is known to be contaminated by process fluid (e.g., the diaphragm has ruptured, the oil is discolored, etc.) drain the oil by opening the oil drain valve below the base at the back of the pump.
7. Remove the suction and discharge check valves as described in Section 7.3.1. Pour out any liquids retained by the check valves into a suitable container, continuing to follow safety precautions as appropriate.
8. Attach lifting means (e.g., straps, rigging and hoist) to support the reagent head during removal.
9. Remove the 10 nuts that secure the reagent head to the pump head.



**OIL MAY LEAK OUT BETWEEN THE PUMP HEAD AND REAGENT HEAD AS THE REAGENT HEAD BOLTS ARE LOOSENED.**

10. Carefully slide the reagent head straight off towards the end of the studs, please use caution not to damage the threads.
11. Rinse or clean the reagent head with an appropriate material/method.
12. Remove and inspect the diaphragm. It may have taken a permanent convex or concave set as a result of normal flexure and conformance to the dish plate. This condition is normal and is not cause for replacement.



**The diaphragm must be replaced if it is excessively deformed, dimpled, or obviously damaged.**

13. Ensure that the critical sealing areas of the diaphragm, reagent head, and pump head are clean and free of debris.
14. When reinstalling a used diaphragm it is important to maintain the previous orientation relative to the reagent head and pump head hole pattern.
15. Place the diaphragm into the circular groove in the reagent head press firmly around the outer edge. The groove will hold the diaphragm in place until you install the reagent head to the pump head.
16. Carefully move the reagent head into place over the studs.
17. Install the reagent head hold-down nuts finger tight (just in contact with the reagent head front face).
18. Torque the nuts in an alternating pattern as defined in *Appendix III*. Initially torque the nuts to one half the recommended value. Repeat the pattern, tightening the nuts to the specified value.
19. Re-install the suction and discharge check valves.
20. Re-install the suction and discharge piping.
21. Re-prime the pump following the procedure outlined in the next section.

## 7.2 Re-Priming the Pump Head

The *PulsaPro* must maintain hydraulic prime to operate properly. While its Hydraulic System includes several components to protect its prime – the HPV, HBV and PTP – they will not automatically restore hydraulic prime if the oil is drained from the hydraulic chamber (the space between the piston and the diaphragm). This would commonly occur when the diaphragm is replaced for example. This procedure describes how to efficiently re-prime the Pump Head.



TIP

**Re-Priming the Pump Head is not required when performing a normal oil change. Typically the Pump Head hydraulic chamber will retain its prime while you drain the oil using the drain valve in the Gear Box.**



TIP

**This procedure may be helpful in cases where the system has experienced a severe upset (for example, when a valve in the suction line is shut off for more than 30 minutes).**

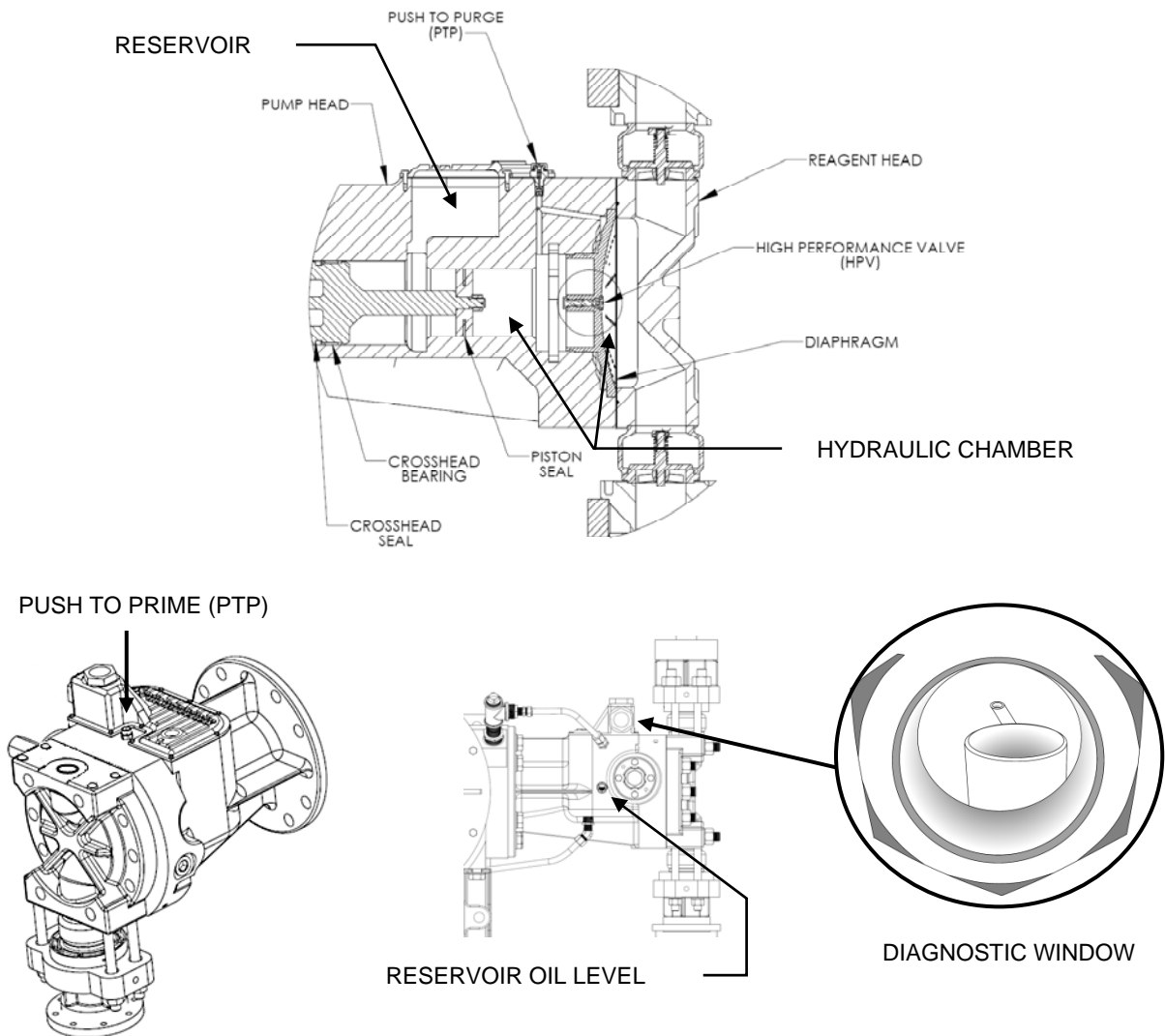

Figure 13

## 7.2.1 Re-Filling the Hydraulic System

Use the following procedure to refill the Hydraulic System after Diaphragm/Piston service or extreme system upset conditions:

1. Disconnect the power source to the drive motor (e.g., lockout/tagout the motor disconnect).
2. Check the Pump Head Oil Level (refer to Section 6.1.3 *Oil Changes*). Restore levels in the Pump Head Reservoir if necessary.
3. Remove the PTP valve from the Pump Head carefully to access the Hydraulic Chamber. There is an o-ring and copper gasket that need to be properly handled and protected from damage.



**OIL MAY LEAK OUT FROM AROUND THE PTP VALVE. TAKE APPROPRIATE MEASURES TO CAPTURE AND CONTAIN IT.**

4. Set the stroke length adjustment to 0%.
5. Using a small plastic funnel (or a kitchen style turkey baster), slowly pour PULSAube Universal IHG (or oil specific to your application) into the Hydraulic Chamber through the PTP valve port until full. Make sure the neck of the funnel enters the small hole at the bottom of the threaded bore. Failure to do so will result in the oil running through a small cross drilled hole into the Reservoir instead of the Hydraulic Chamber.
6. Replace the PTP valve, ensuring that the flat copper gasket and o-ring are properly in place.

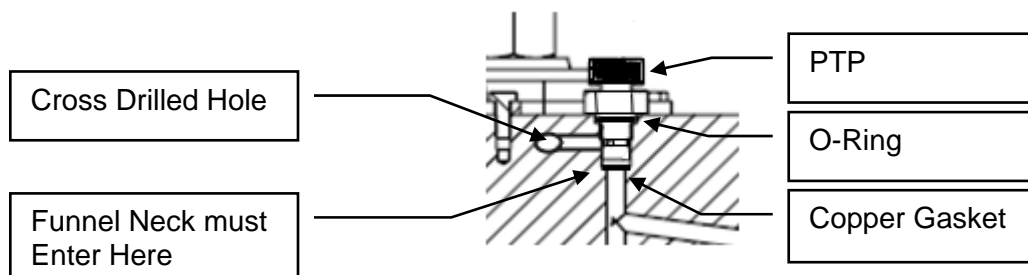

## 7.2.2 Re-Priming the Hydraulic System

Use the following procedure to re-prime the Hydraulic System:

1. Restore power to the pump.
2. Turn on the pump and slowly adjust the stroke length to 50%.
3. Allow the pump to operate for 30 minutes. During this time fully depress and hold the PTP valve button for several seconds every 5 minutes. After approximately 15 minutes oil should begin to flow out of the small diagnostic port (refer to Figure 13) but may appear foamy. By the end of the 30 minute period oil coming out of the diagnostic port should be clear of bubbles. Depending on the system discharge flow and pressure oil may spurt from the diagnostic port. This is normal.
4. Adjust the stroke length to 100%. Confirm the pump is making the proper flow and pressure using external equipment - a flow meter and pressure gage for example.
5. If the pump is NOT making flow and pressure repeat this re-priming procedure.
6. If, after attempting a second re-prime, the pump still doesn't make flow and pressure, repeat the Re-Fill and Re-Prime procedures above.

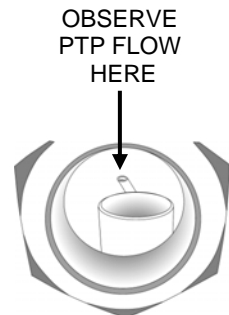

## 7.3 Check Valves

Most fluid metering problems are related to check valves. Problems can be caused by solids accumulation between the valve and seat, corrosion of seating surfaces, erosion, physical damage due to wear or the presence of foreign objects.

There are two styles of check valves. Ball checks are used for lower flows. Disk checks are used for higher flows.

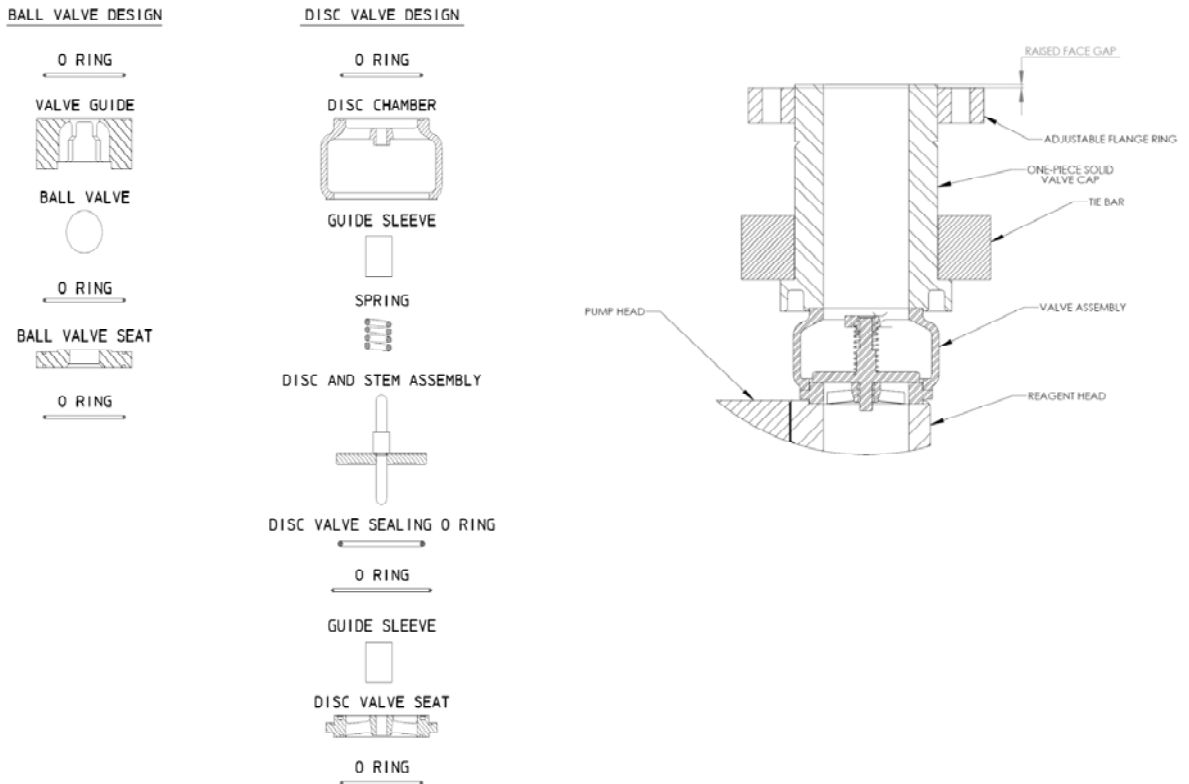

Figure 14

The ball check valve incorporates a ball, guide, and seat. Flow in the unchecked direction lifts the ball off the seat, allowing liquid to pass through the guide. Reverse flow forces the ball down, sealing it against the sharp edge of the seat. The guide permits the ball to rotate but restricts vertical and lateral movement in order to minimize “slip” or reverse flow. Ball rotation prolongs life by distributing wear over the entire surface of the ball. Since ball return is by gravity, the valve must be in the vertical position in order to function properly. Parts are sealed by o-rings.

The disk valve functions in the same manner as the ball valve, except that the ball is replaced by a spring-loaded guided disk. The seat may contain a captured o-ring to facilitate sealing.

### 7.3.1 Check Valve Removal



**TAKE ALL PRECAUTIONS TO PREVENT ENVIRONMENTAL AND PERSONNEL EXPOSURE TO HAZARDOUS MATERIALS.**

1. Disconnect the power source to the drive motor (e.g., lockout/tagout the motor disconnect).
2. Relieve all pressure from the piping system.
3. Close the suction and discharge shutoff valves (refer to *Figure 8A*).
4. Loosen the suction valve tie-bar bolts and spring the suction piping slightly to drain any liquid from the reagent head cavity. If the piping is closely connected it may be necessary to disconnect a union or flange.
5. Remove the suction check valve assembly, holding it together as a unit.
6. Loosen the tie bar bolts on the discharge valve and spring the piping slightly to drain any liquid.
7. Remove the discharge check valve assembly, holding it together as a unit.

### 7.3.2 Ball Valve – Inspection and Repair

1. Disassemble both the suction and discharge check valves.  
The ball seats should have sharp edges or a small chamfer and be free from dents or nicks.
2. Examine components for wear by holding the ball firmly against its mating seat in front of a bright light to inspect for fit.



**Observation of light between the ball and seat is cause for replacement of either or both components.**

3. Reassemble both valves using new parts as required. The o-rings should always be replaced.

### 7.3.3 Disk Valve – Inspection and Repair

1. Disassemble valves and inspect components for wear.  
The seats and lower disk surfaces contacting the seats should remain flat and smooth. Although it is normal for the o-ring in the seat to be flattened after significant use, replacement is recommended as a part of valve maintenance.
2. The seat o-ring is captured by an internal lip in its groove in the seat. Removal requires the following destructive procedure:
  - a) Position a small blade type screwdriver against the outer edge of the o-ring at an angle of approximately 45 degrees.
  - b) Taking care not to damage the sides of the seat, drive the screwdriver into the o-ring.
  - c) Using the screwdriver, pry one section of the o-ring out of the groove.
  - d) Grip the O-Ring with pliers, and remove it from the seat.
3. To install the replacement seat o-ring; place it on the seat above the groove.
4. Position a flat metal object over the o-ring
5. Apply uniform light pressure using a hand arbor press.

The slight movement that accompanies seating can be easily felt through the press handle.



**DO NOT TRY TO INSTALL THE RING BY HAMMERING, AS THE SEATING WILL NOT BE UNIFORM. THE RING MAY BE DAMAGED AND THE PUMP PERFORMANCE MAY BE IMPAIRED.**

6. Reassemble both valves using new parts as required. Sealing O-Rings should always be replaced.

### 7.3.4 Check Valve Reinstallation

1. Reinstall both valve assemblies, taking care to ensure that they are correctly oriented with balls or disks above seats. Refer to *Figure 14*.
2. Tighten the tie bar bolts evenly, making sure the valve assemblies and tie bar are assembled squarely. Refer to *Appendix III* for torque values.



**NOTE**

**For best results, always loosen the unions or flanges on either side of the system piping prior to re-tightening the check valve assemblies. Retighten the unions or flanges after the check valves are securely tightened into position.**

3. Check for leaks and retighten tie bar bolts as necessary.



## 7.4 Hydraulic Performance Valve (HPV)

During normal pump operation hydraulic fluid is continually discharged through the automatic bleed valve and may also be lost past the piston seals. This causes the diaphragm to be drawn further back on each successive suction stroke until it actuates the HPV. Once the valve is actuated, oil is allowed to flow into the hydraulic system until the piston reaches the end of the suction stroke. As the piston starts forward a Hydraulic Makeup Valve (HMV) prevents oil from flowing back through the HPV, thereby allowing the valve to close as the diaphragm moves forward. Through this process the diaphragm is continually maintained in the proper operating position relative to the pump head dish plate. Since the HPV is unaffected by the vacuum level in the pump head, oil cannot be inadvertently brought into the hydraulic system which would result in over-extension and damage to the diaphragm. This feature provides pump protection should the suction line become intermittently restricted or closed.

*PulsaPro 900* High Performance Valves (HPV) and Hydraulic Makeup Valves (HMV) are factory preset and require no maintenance provided the oil remains clean. Should the HPV require removal for cleaning or replacement follow the below procedure.

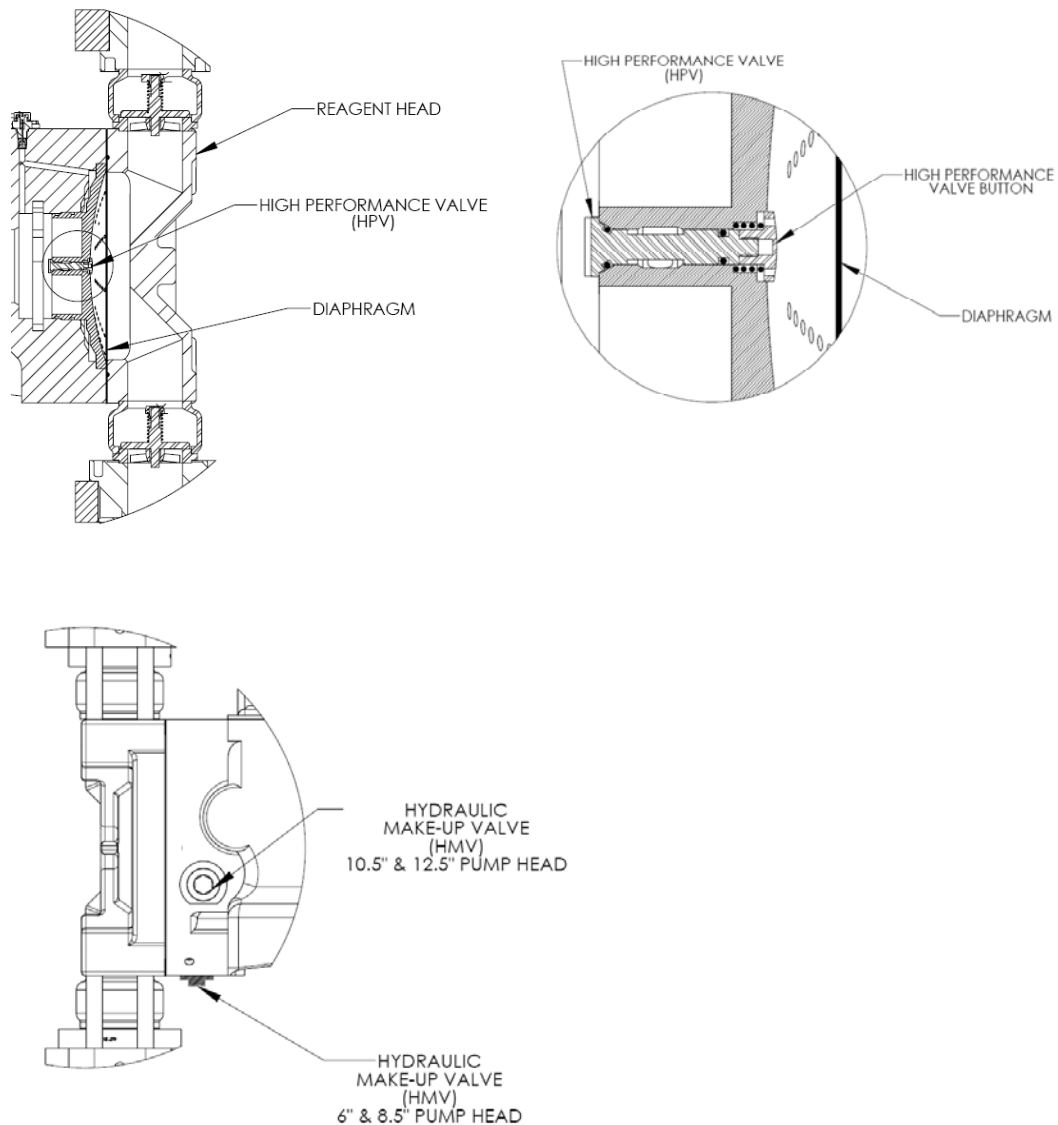
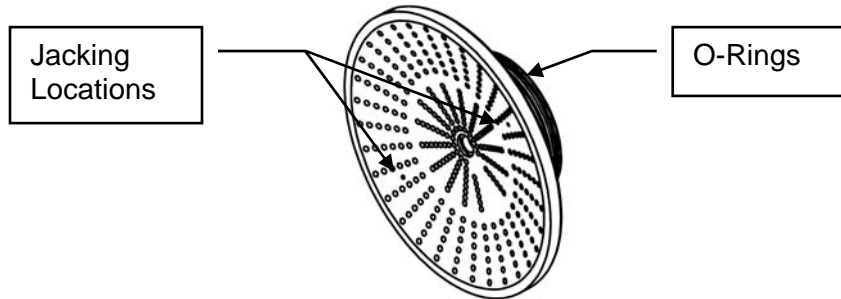

Figure 15

## 7.4.1 HPV Removal and Replacement

1. Disconnect the power source to the drive motor (e.g., lockout/tagout the motor disconnect).
2. Relieve all pressure from the piping system.
3. Drain the oil from the eccentric box / pump head by opening the drain valve.
4. Remove the reagent head and diaphragm using the procedure outlined in Section 7.1.
5. The dish plate is held in the pump head by two sealing o-rings. Install screws into the two M4 x 0.7 threaded jacking locations to remove the HBV / Dish plate assembly properly. Tighten them into the dish plate to jack it out of the pump head. Take care to prevent dropping the dish plate on final removal.



6. If cleaning of *the valve* is required, use a solvent compatible with Nitrile rubber and blow air through the valve to remove all contaminants.
7. Inspect the O-Rings on the body of the valve for nicks or other damage and replace if required.
8. Lubricate the O-Rings with **PULSA**lube Universal or Ultra and carefully insert the HPV into the dish side bore of the pump head.
9. Rotate the valve and dish insert into the pump head until the hole on the back side of the outer edge aligns with the alignment pin. Seat dish in counter bore.

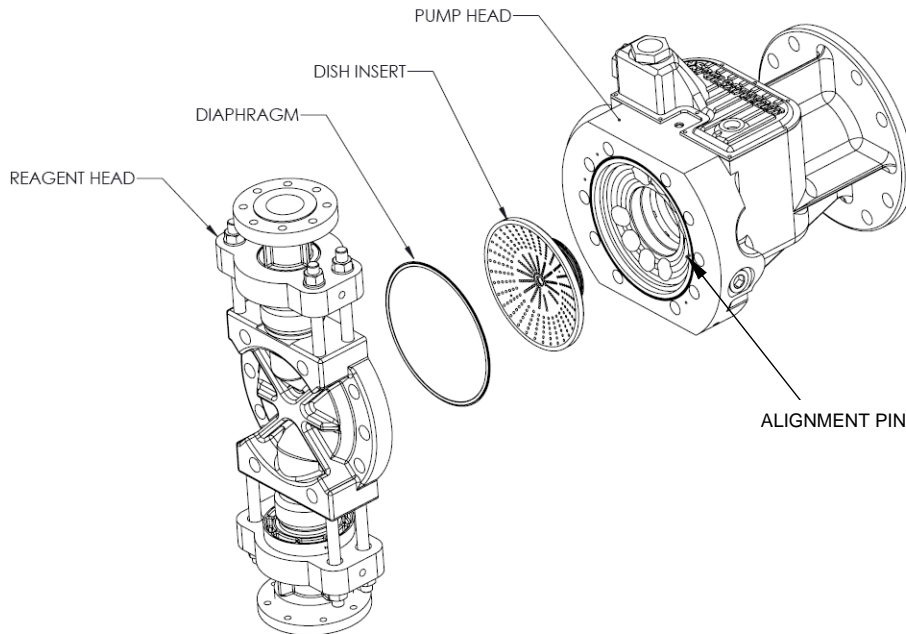

Figure 16

10. Reinstall the diaphragm and the reagent head using the procedure outlined in Section 7.1.
11. Close the Gearbox / Pump Head drain valve and fill with **PULSA**lube Universal or Ultra hydraulic oil.
12. Re-prime the pump head.

## 7.5 Hydraulic Bypass Valve (HBV)

All *PulsaPro* Series pumps incorporate a Hydraulic Bypass Valve (HBV). This valve is designed to protect the pump against excessive hydraulic pressure encountered during system upset (it will not limit or regulate system pressure). It is constructed of an adjustable spring loaded valve ported into the hydraulic cavity of the pump head. The valve is factory-set at 10% above the rated pump discharge pressure or as specified at the time of order.

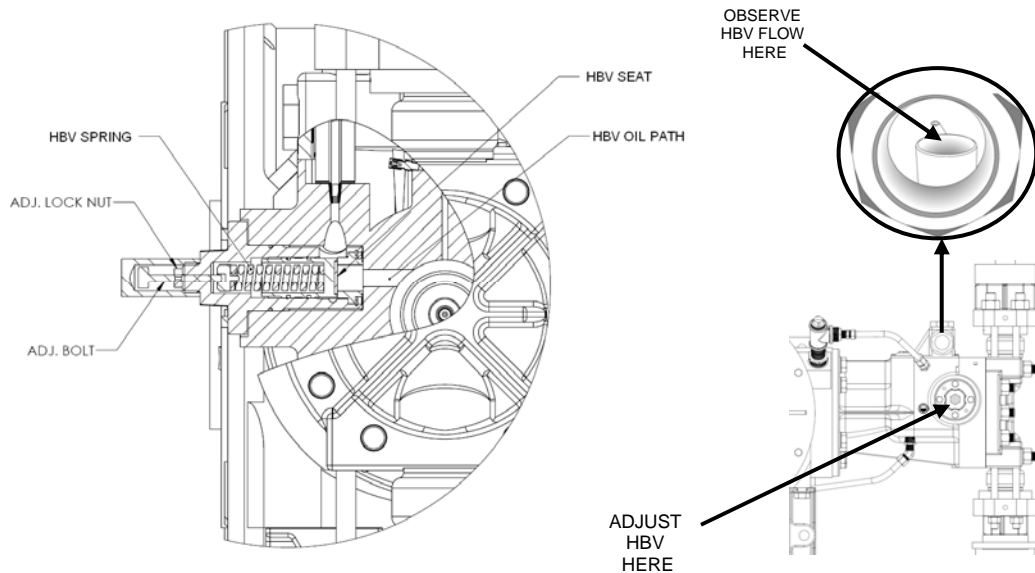

Figure 17

The HBV is located on the left side of the pump head as you face the reagent head. Discharge from this valve is visible through a large diameter tube located behind the diagnostic port that faces the same side of the pump (refer to figure 17). Whenever discharge is visible, it indicates the pressure in the pump discharge piping exceeds the HBV setting. After confirming the discharge pressure is within the rated pressure of the pump it may be necessary to adjust the HBV setting.

Adjusting the HBV Valve:

1. Remove the valve adjustment cover.
2. Loosen the locknut.
3. Tighten the adjustment bolt by turning clockwise (as seen facing the screw) to increase the bypass pressure. Loosen the bolt by turning counterclockwise to decrease it.
4. Re-tighten the locknut after adjustment.
5. Re-install the valve adjustment cover.

Pump damage may occur during a system upset if the hydraulic bypass pressure is set higher than 10% over the design pressure of the pump (refer to the nameplate rating). Conversely, if

the setting is too low the valve will operate on each discharge stroke. This results in decreased pumping capacity and will eventually affect the efficiency of the valve.

To check the hydraulic bypass pressure setting, install a gauge and a back pressure valve in the pump discharge line. The gauge must be between the pump and the back pressure valve (for convenience, locate the two as close to the pump as possible). With the pump operating at maximum stroke length, gradually increase the discharge pressure and observe when the HBV starts to operate through the diagnostic window. The cracking pressure of the valve must be at least as high as the maximum pressure of the system but no more than 10% over the pump's rated pressure. After adjustment tighten the lock nut and reinstall the metal cover.

Periodic inspection of the valve seat is recommended. If it becomes worn or damaged leakage will occur regardless of how tightly the valve is adjusted.

### 7.5.1 PTP (Push To Purge) Valve

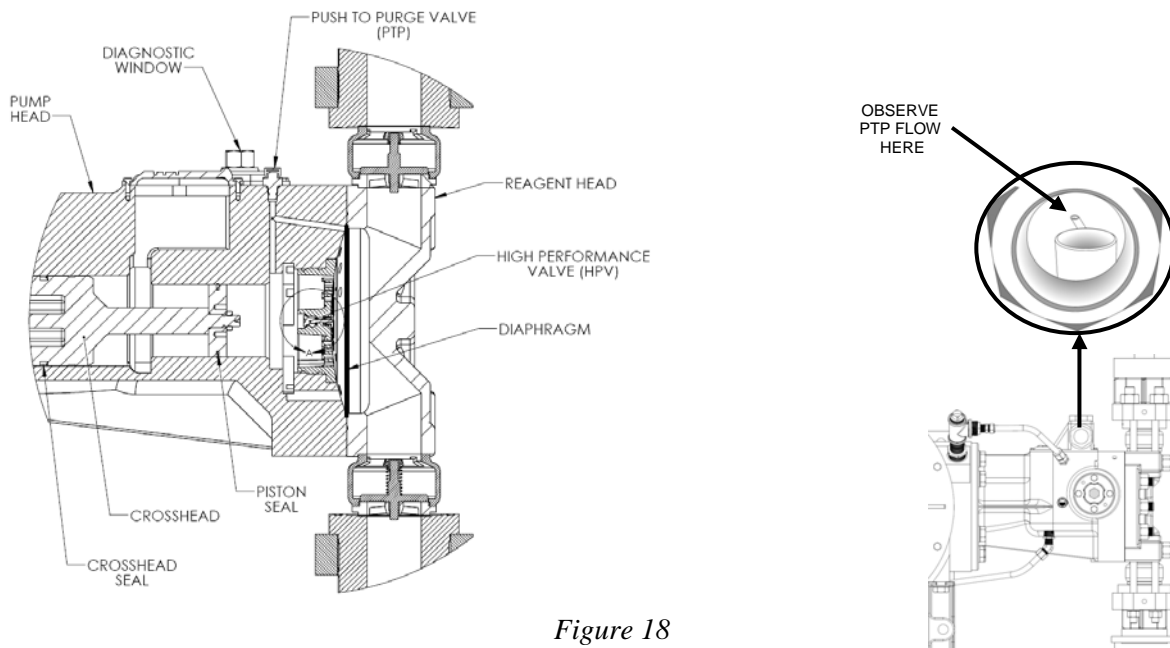

Figure 18

The PTP (Push to Purge) Valve is a gravity-operated disk check valve that automatically removes gases from the hydraulic system. On each discharge stroke of the pump, pressure generated by the piston lifts the disk off a lower seat. If accumulated gasses are present the gasses flow around the disk and are vented to the reservoir. If there are no gasses present then oil forces the disk to shut off against an upper seat – limiting the amount of fluid that escapes. On each suction stroke, the disk returns (by gravity) to the lower seat to prevent reentry of gas into the system. By this mechanism, under normal operation, a small amount of oil is displaced with each discharge stroke. This oil is returned by gravity to the reservoir where it is recycled. The PTP removes minute accumulations of gas long before they are visible or detrimental to pump operation.

The PTP includes a spring-loaded button at the top of the valve that is used to accelerate the purging of accumulated gasses in the hydraulics. Holding the button down momentarily opens the disk valve so that large amounts of gas and hydraulic fluid can be instantly purged. When the button is released, the valve returns to normal automatic operation. PTP operation can be monitored by observing oil flow through the small tube behind the diagnostic window.

## 7.5.2 PTP Removal, Cleaning, and Reinstallation



**Any accumulation of solids can cause the valve to malfunction.**

NOTE

1. Disconnect the power source to the drive motor (e.g., lockout/tagout the motor disconnect).
2. Relieve all pressure from the piping system.
3. Slowly unscrew the valve to gradually relieve any residual hydraulic system pressure.



WARNING

**OIL MAY LEAK OUT FROM AROUND THE PTP VALVE. TAKE APPROPRIATE MEASURES TO CAPTURE AND CONTAIN IT.**

4. Remove the valve and clean it by soaking in a petroleum based solvent.  
Valve operation can be confirmed by blowing air through it in both directions and listening for the “click” sound of disk-seat contact in both directions.
5. Verify that the copper gasket is installed at the bottom of the threaded hole in the pump head.  
The copper gasket need not be replaced provided that it is sound and undamaged.  
The elastomeric gasket around the upper portion of the valve assembly may be likewise re-used.



NOTE

**This valve is not repairable and must be replaced if it continues to malfunction after cleaning.**

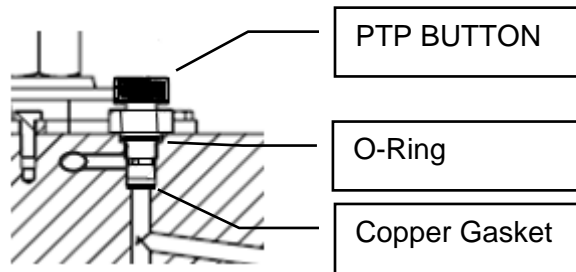
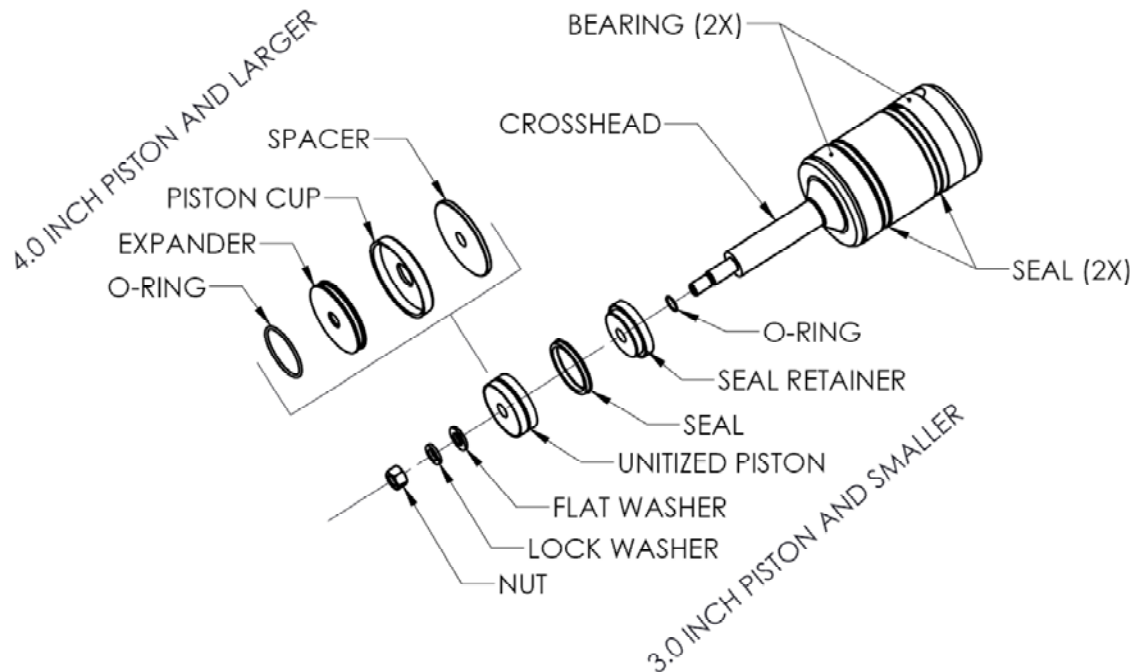

*Figure 18a*

## 7.5.3 Piston Seal

### 7.5.3.1 General Description

The piston assembly has 2 different design structures as shown in *Figure 19*. With proper maintenance, piston seals should give you years of service.



*Figure 19*

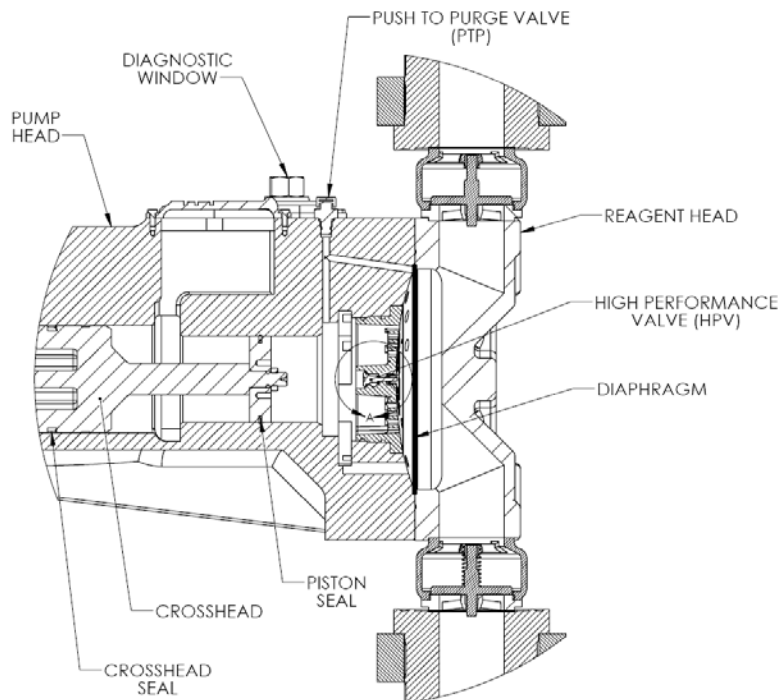

*Figure 20*

## 7.5.4 Piston Removal

Piston Removal Procedure:

1. Remove reagent head, and dish plate using the procedure defined in *Section 7.4.1, HPV Removal*.
2. Remove the nut from the end of the cross head shaft assembly.
3. Set the stroke adjustment setting to 100%.
4. Rotate the Motor by hand (confirm lockout/tag out) until the piston achieves its full forward position.
5. Continue Motor rotation until the cross head shaft is pulled from the hole in the center of the piston assembly.
6. Hook the piston assembly through hole in center and pull the piston straight out of the piston bore by exerting even tension.

## 7.5.5 Piston Seal Reinstallation

Piston Reinstallation Procedure:



**It is important to apply an anaerobic thread locking compound (Loctite® 242™ Henkel Corporation) to the threads of the hex nut and torque to 140 foot-pounds to prevent loosening during operation.**

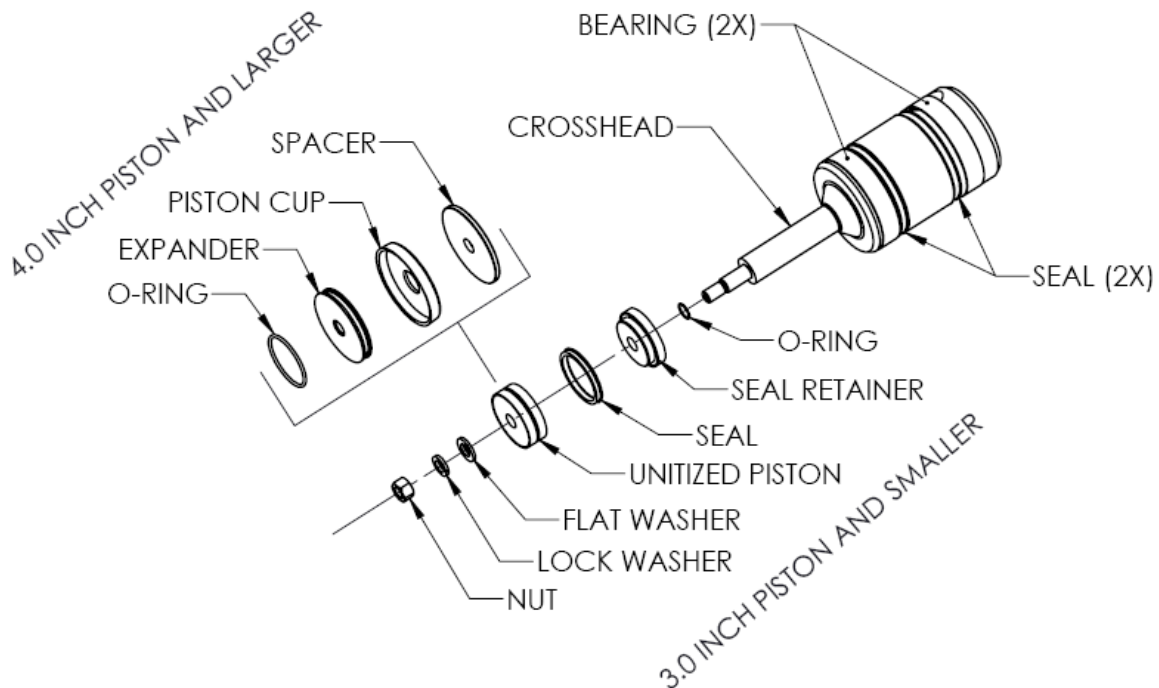

Figure 21

1. Apply **PULSAlube Universal or Ultra** hydraulic oil to all the piston assembly components. No matter which piston size you have.

***For 4 inch pistons and larger please follow these instructions:***

- 1.1 Slide the smaller of the 2 o-rings over the threaded end of the cross head.
- 1.2 Install the spacer onto the threaded end of the cross head.
- 1.3 Install the piston cup with the outer lip facing away from the cross head.
- 1.4 Install the larger o-ring into the groove on the outside diameter of the Expander.
- 1.5 Install the expander onto threaded end of the cross head.
- 1.6 Assure all components slide back onto the threaded end of the cross head until they bottom out (refer to Figure 21).
- 1.7 Please confirm that the expander with the o-ring on the outside diameter lies flat inside the piston cup when fully pushed rearward. Proceed to Step 2 of this section.

***For 3 inch pistons and smaller please follow these instructions:***

- 1.1 Slide the smaller of the 2 o-rings over the threaded end of the cross head.
  - 1.2 Install the seal retainer onto the threaded end of the cross head.
  - 1.3 Install the seal onto the seal retainer. Make sure the seal is seated properly all the way around the retainer.
  - 1.4 Install the unitized piston.
  - 1.5 Assure all components slide back onto the threaded end of the cross head until they bottom out (refer to Figure 21).
  - 1.6 Please double check the seal to assure it is seated properly to the seal retainer. Proceed to Step 2 of this section.
2. Install the flat washer and lock washer onto the end of the threaded shaft.
  3. Apply Loctite® 242 (™ Henkel Corporation) removable anaerobic thread locking compound to the threads on the threaded end of the Cross head.
  4. Hand tighten the Piston retaining nut onto the threaded end of the cross head.
  5. Torque the nut to 140 foot-pounds. This will draw the piston onto the end of the cross head and cause it to bottom out on the shoulder.



**IT IS IMPORTANT TO USE THE CORRECT THREAD LOCKING COMPOUND AND TORQUE THE PISTON RETAINING NUT. FAILURE TO DO SO CAN RESULT IN CATASTROPHIC FAILURE OF THE PISTON ASSEMBLY AND RESULT IN DAMAGE THAT IS NOT COVERED UNDER WARRANTY.**

6. Replace the reagent head and diaphragm as described in *Section 7.1, Wet End Removal, Inspection and Reinstallation*.
7. Fill the pump head with **PULSAlube Universal or Ultra** and prime the pump head as described in *Section 6 – Equipment Startup*.



## 7.6 Oil Seals

### 7.6.1 General Description

The *PulsaPro 900* gear box has seven primary oil seals. Six of these are static o-ring seals. Only one (the Worm Oil Seal) is dynamic and should be serviced at regular intervals.

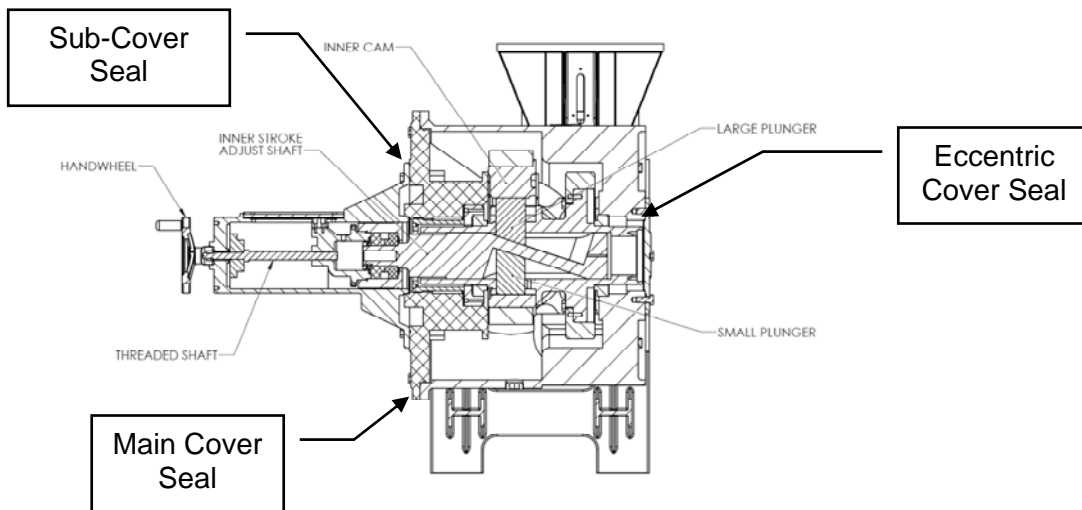
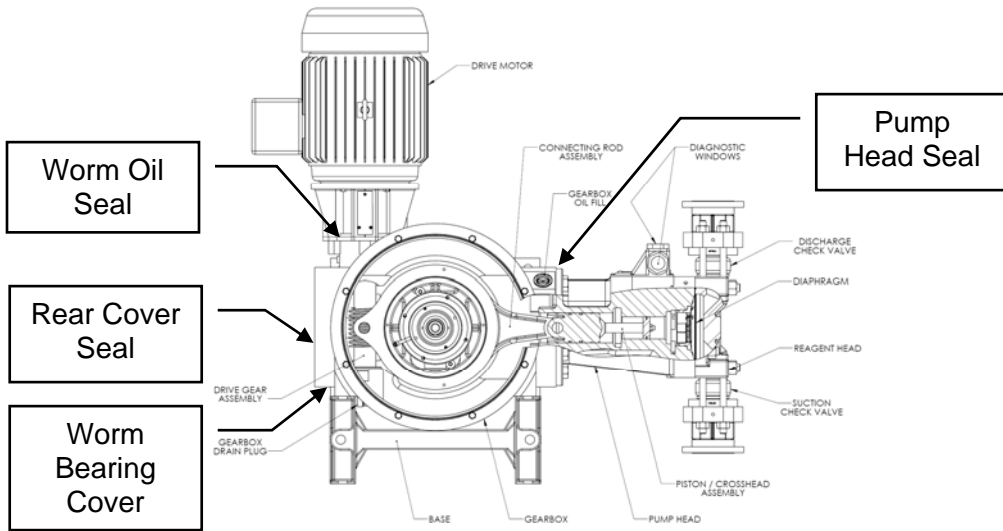
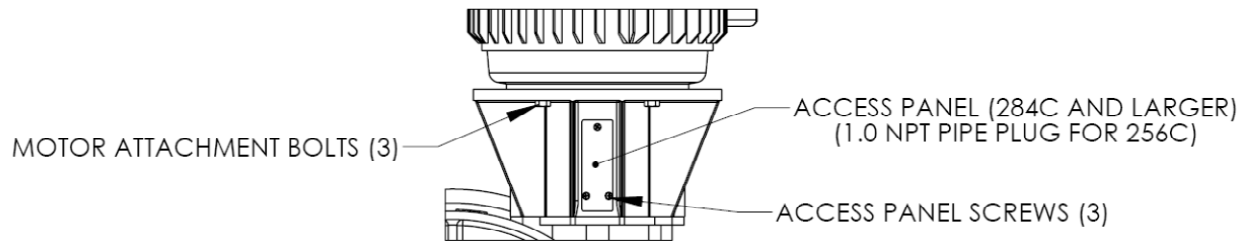

Figure 23

## 7.6.2 Motor Adaptor Oil Seal Removal and Replacement

### 7.6.2.1 Motor Adaptor Removal and Worm Oil Seal Replacement

1. Disconnect the power source to the drive motor (e.g., lockout/tagout the motor disconnect).
2. Attach required lifting device to the motor. Do not put any tension on the pump motor at this time.
3. Remove the four Motor Attachment Bolts from the motor (refer to *Figure 24*).
4. Open the Access Panel by removing the three Access Panel Screws.



*Figure 24*

5. Remove the Motor and Upper Coupling assembly by lifting straight up.
6. Remove the four motor adaptor bolts and lift the motor adaptor from the gearbox.
7. Rotate the Lower Coupling Assembly by hand until the Coupling Setscrew is visible.
8. Loosen the Lower Coupling Setscrew.
9. Remove the lower coupling and coupling spider.

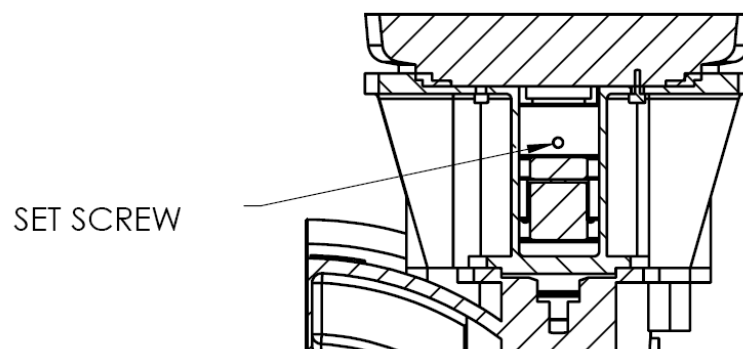

*Figure 25*

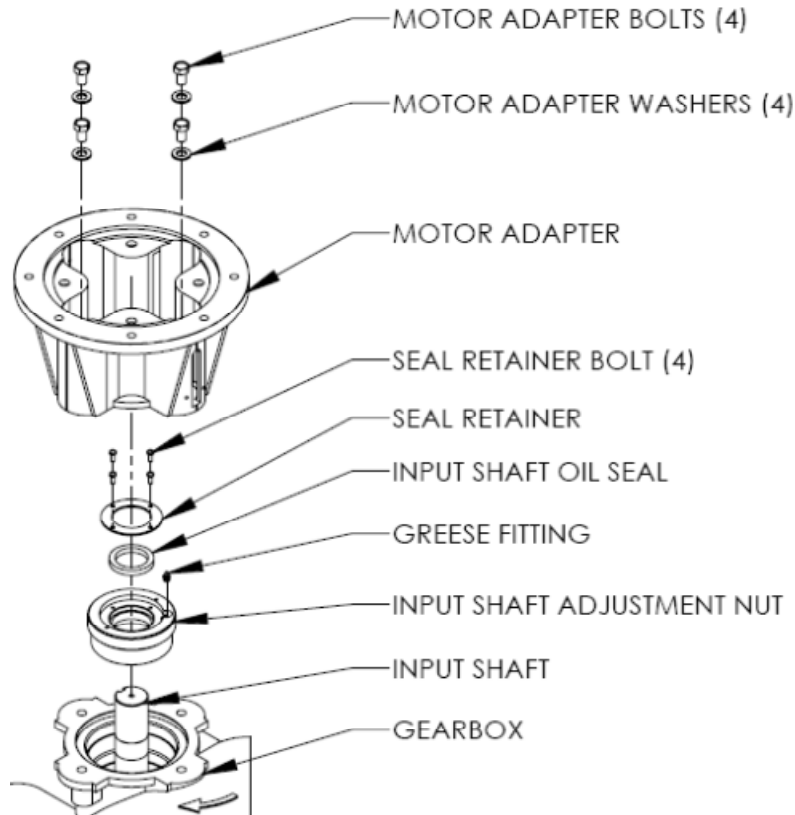

Figure 26

10. Remove the four seal retainer bolts and seal retainer.
11. Remove the input shaft oil seal from the input shaft adjustment nut.
12. Lubricate the replacement input shaft seal with silicone grease or **PULSaLube Universal or Ultra**.
13. Slide the input shaft adjustment nut onto the input shaft and begin tightening. The input shaft adjustment nut should have about .002in (0.05mm) max end play.
14. Install the input shaft oil seal by pressing it into position. Be careful not to cut the seal on the key way of the shaft.
15. Install the Motor Adaptor over the gearbox input shaft and then bolt in place.
16. Slip the Lower Coupling and Spider over the input shaft.
17. Position the coupling half flush to the end of the input shaft.
18. Tighten the coupling setscrew.
19. Lower the motor / Upper Coupling into position. As you are positioning the motor, it may be necessary to rotate the Lower Coupling / Spider assembly to facilitate proper alignment.
20. Once the coupling is aligned, lower the motor assembly until full contact has been made with the lower coupling.
21. Insert and tighten the motor mounting bolts that were removed in Step 3.
22. Restore power to the *PulsaPro 900* pump assembly.

## 7.7 Stroke Control Assembly

### 7.7.1 Stroke Control Assembly Maintenance

The stroke adjust housing has grease fittings that will need to be maintained.  
(Refer to Figure 27).

1. Disconnect the power source to the drive motor (e.g., lockout/tagout the motor disconnect).
2. To access the grease fitting remove Qty 6 lens cover bolts.
3. Remove the protective lens cover.
4. Adjust the stroke setting from 100 % down to approximately 65%. The grease fitting should be visible in the slot that the stroke setting indicator rides in.
5. Use a standard grease gun to inject Heavy Duty Grease (e.g., NLGI #2 Lithium Complex Grease) until resistance is felt.
6. Use a standard grease gun to inject Heavy Duty Grease (e.g., NLGI #2 Lithium Complex Grease) into grease fitting "A" until grease is seen squeezing out from gear area. To observe the gear area in the stroke adjust housing remove the stroke lock mechanism from the stroke adjust housing. **See Figure 27 Right picture.**

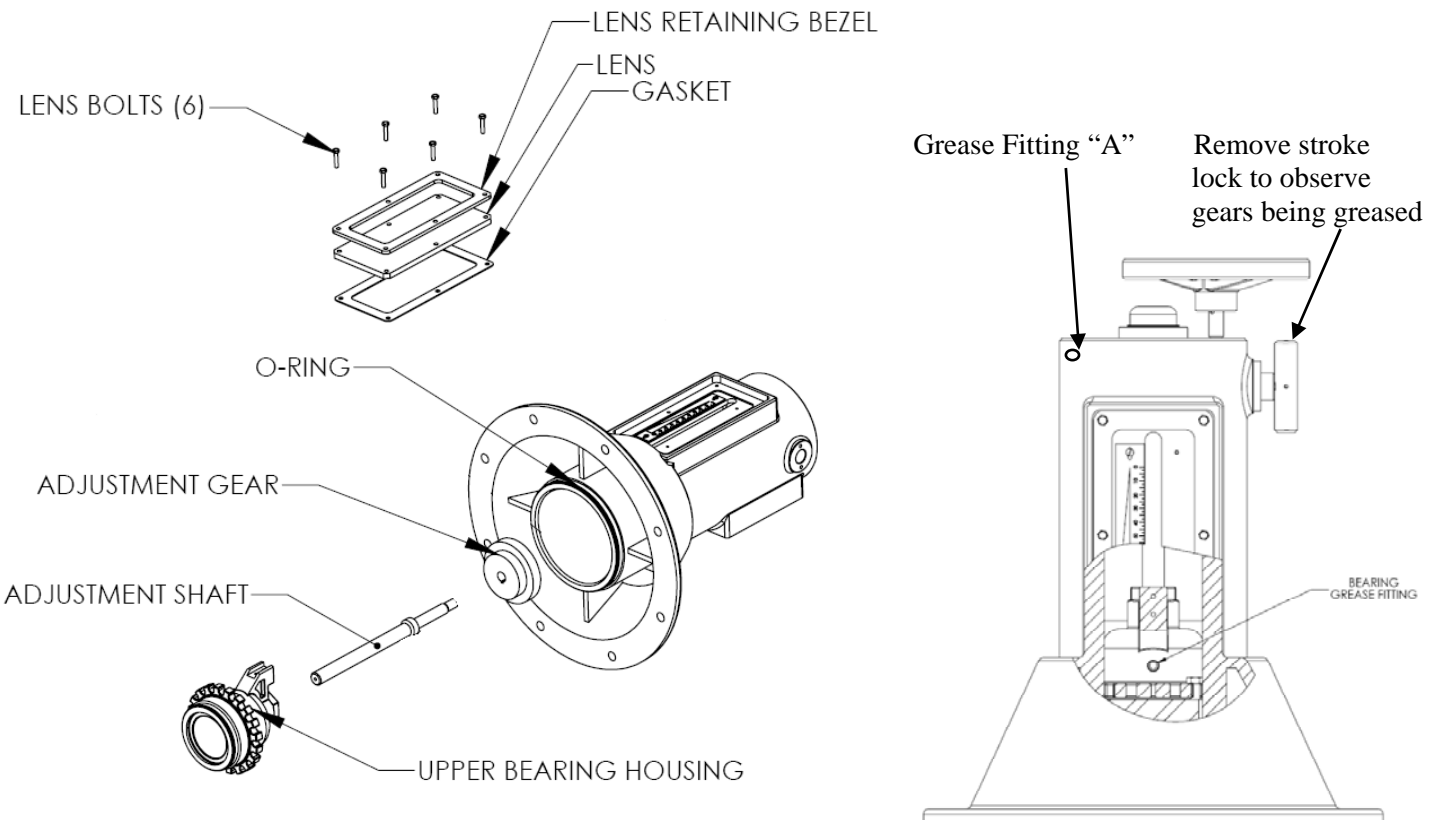

*Figure 27*

## 7.8 Motor Removal and Reinstallation

1. Disconnect the power source to the drive motor (e.g., lockout/tagout the motor disconnect).
2. Disconnect the motor wiring from the motor.
3. Attach required lifting device to the motor. Do not put any tension on the pump motor at this time.
4. Remove the four Motor Attachment Bolts from the motor (refer to *Figure 24*). Some European motors will have eight bolts
5. Open the access panel by removing the three access panel screws to expose the coupling.



**The coupling is an interlocking jaw design and uses an elastomeric spider between the two coupling halves. The upper half of the coupling remains on the motor shaft and the lower half stays on the worm gear shaft.**

6. Lift the motor from the mounting adaptor.
7. If the motor is to be replaced, position the “old” motor so that the upper coupling is accessible.
8. Loosen the upper coupling setscrew to allow removal of the upper coupling half, taking care to not lose the shaft key.
9. Install the upper coupling half on the shaft of the replacement motor, ensuring that the shaft key is in place.
10. Align the end of the shaft flush with the inner surface of the coupling and tighten the setscrew.
11. Reinstall the motor by reversing the steps above.

## 8. Replacement Parts

### 8.1 PulsaPro Series KOPkit Program

*PulsaPro* Series **KOPkits** contain all replacement parts normally used in a preventative maintenance program.



***PULSA*lube Universal or Ultra is available for preventative maintenance programs. Refer to the Equipment Startup section.**

There is a specific **KOPkit** for every *PulsaPro* Series pump model. When practical, each **KOPkit** is vacuum-packed for extended storage.

All *PulsaPro* Series pumps will have the **KOPkit** number identified on:

- a) the pump nameplate,
- b) the specification data sheet, and
- c) the Pulsafeeder order documents.

**KOPkits** can also be selected from the technical data sheet shipped with the pump or by a Pulsafeeder representative.

### 8.2 Ordering KOPkits or Parts

When ordering replacement parts always specify:

- a) Pump model and serial number (stamped on pump nameplate), e.g., Model No. PRO9000000X with Serial No. X775123.
- b) Part number and description from the *PulsaPro* Series parts list. Include the three-character suffix.(TNR)



***PulsaPro* Series part numbers begin either with the letters “NP”, “RS” or the letter “W”, e.g., NP170001-TNR or W210221-001.**

## 9. PULSAlarm Leak Detection Assembly

The PULSAlarm leak detection assembly consists of a reagent head, leak detection diaphragm, fill port, and pressure switch and gauge. The reagent head, diaphragm, suction and discharge check valves are the only parts of the pump to contact the process liquid - consequently, maintenance is critical to pump performance.

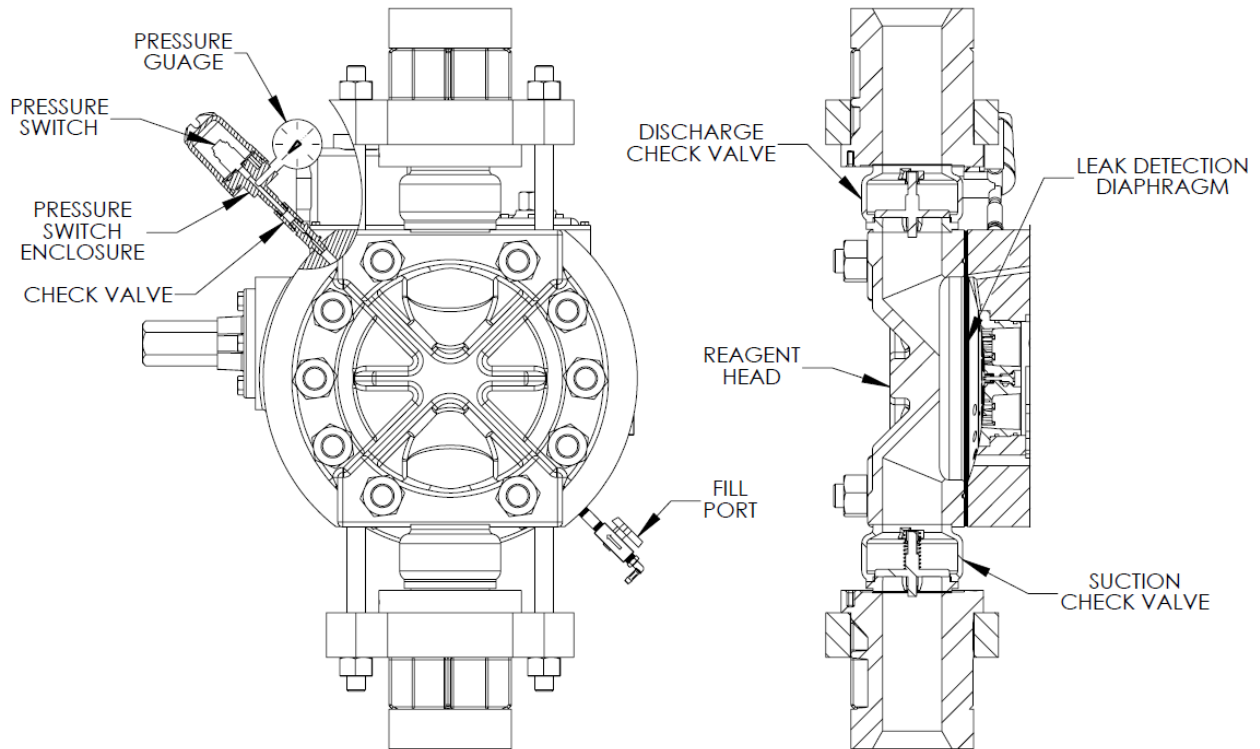

Figure 24



**A SEALED SYSTEM MUST BE MAINTAINED AT ALL TIMES DURING PUMP OPERATION, WHETHER LEAK DETECTION IS REQUIRED OR NOT. IF A SEALED PRESSURE SYSTEM IS NOT PRESENT, DECREASED FLOW AND/OR DIAPHRAGM DAMAGE WILL OCCUR. PLEASE NOTE THAT THE FACTORY SET POINT FOR ACTUATION OF THE PRESSURE SWITCH IS 25 PSIG.**

## 9.1 PULSAlarm Leak Detection Diaphragm

Double, or sandwiched, TFE diaphragms are sealed at their peripheries to an intermediate metal spacer ring. The space between the diaphragms is sealed so that the diaphragm functions in a manner similar to a standard single diaphragm. In the pressure system, the space between the diaphragms is filled with a small amount of fluid. At startup, any excess fluid in the system is expelled through the check valve. Once the excess is removed the system is capped and sealed. The fluid as supplied from the factory is **Silicone LD**, but an alternate fluid can be used if compatibility with the materials of construction is verified. This space is connected to an adjustable electrical switch (optional) that actuates in response to buildup of pressure resulting from rupture of either or both diaphragms. Switch operation can be used to perform any external function, typically to signal an alarm or turn off the pump. For component location refer to *Figure 24*.

## 9.2 Leak Detection – Setup for Pressure

Pumps incorporating pressure leak detection are shipped from the factory with the system fully set up to work at full pump pressure. No further setup is required. The standard factory barrier fluid is **Silicone LD**, if any other customer-specified media is used it must be compatible with construction materials. The system will require proper setup after maintenance or repairs see section 9.3 on the following page for the proper procedure.

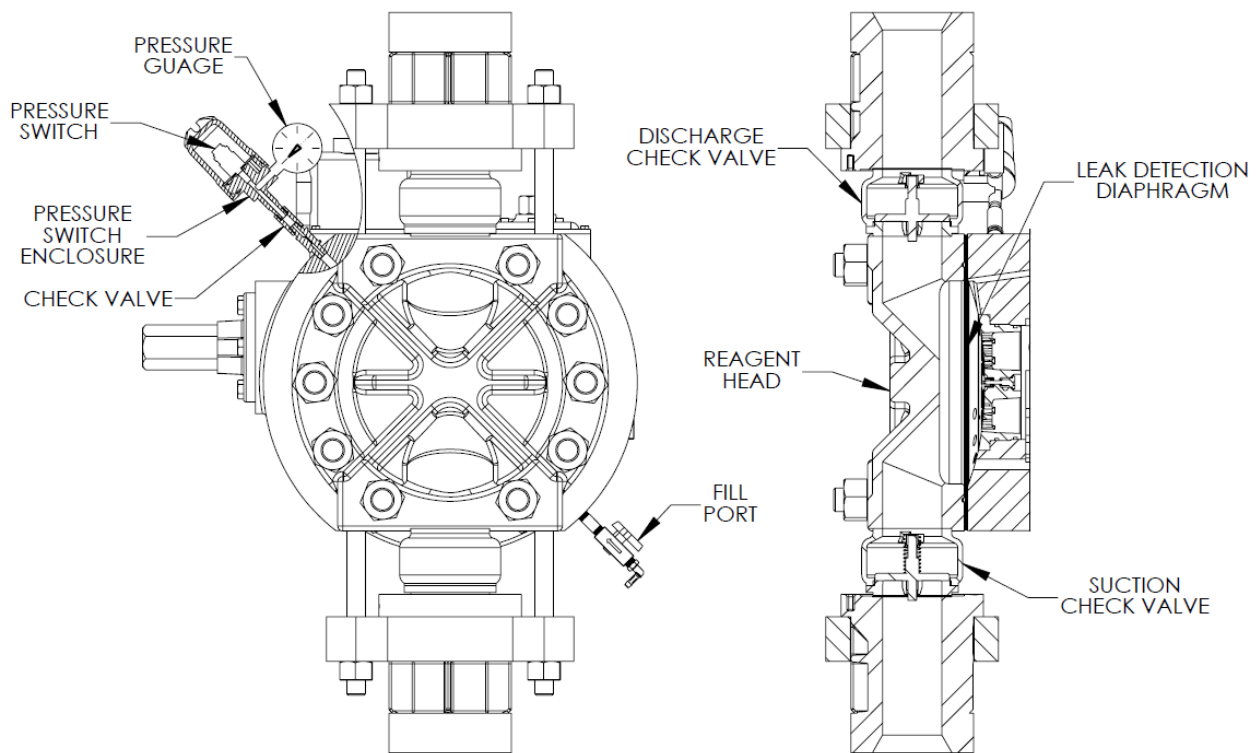

Figure 25





**If the pressurized leak detection system is opened to the atmosphere during maintenance or inspection, the system must be re-primed properly to avoid diaphragm damage and ensure proper leak detection operation and system performance.**



**THE STANDARD FACTORY INTERMEDIATE FLUID IS SILICONE LD. IF ANY OTHER CUSTOMER-SPECIFIED MEDIA IS USED, IT MUST BE COMPATIBLE WITH THE MATERIALS OF CONSTRUCTION. REFER TO THE FLUID MANUFACTURER'S LITERATURE FOR APPROPRIATE SAFETY PRECAUTIONS.**

**Use the following procedure to set-up the pressurized leak-detection system:**

1. Complete re-assembly of the diaphragm, reagent head, and external components. **Ensure that reagent head and tie-bar bolts are tightened according to the appropriate torque specifications** (consult Appendix III)
2. Remove the pressure gauge from the housing body and replace with the straight tubing connection supplied with the pump. Connect a vacuum supply (hand vacuum pump) to the tube fitting.



**If the system was previously sealed, you may need to remove the plug and re-install the hose fittings at the fill port. There should be a container in the vacuum line to trap excess barrier fluid. An inexpensive automotive brake bleeding kit is appropriate for this purpose.**

3. Connect the fill tube to the fill valve tube connection. Any short length of the appropriate sized tubing may be used for this purpose.
4. Open the fill valve.
5. Place the fill tube into a container of the barrier fluid being used.
6. Apply vacuum, the fluid should rise into the fill tube and enter the system.
7. Observe the fluid at the exit (vacuum pump) side. When clear, air free fluid is observed, close the fill valve, while maintaining the vacuum on the system to begin the process of drawing out excess fluid.



**If you are re-using a previously installed diaphragm, it will take time for the Silicone LD fluid to migrate through the system, be patient!**

8. Release the vacuum, and remove both the fill tube and the vacuum pump from the fittings.
9. Empty the fill tube of fluid, and place it on the fitting near the switch, extending upwards, and open to the atmosphere.
10. Ensure that the eccentric box of the pump has been filled to the appropriate level with the correct hydraulic fluid.
11. Adjust the pump to the zero stroke (0%) position.

12. **If the pump is not already hydraulically primed**, remove the PTP valve from the top of the pump head. Using a plastic funnel or similar, slowly pour hydraulic fluid into the pump head cavity until full. The end of the funnel should fit into the small diameter hole at the bottom of the PTP socket – not the larger threaded diameter. The threaded diameter includes a side drain passage that will prevent oil from entering the pump head if used. Alternatively apply a

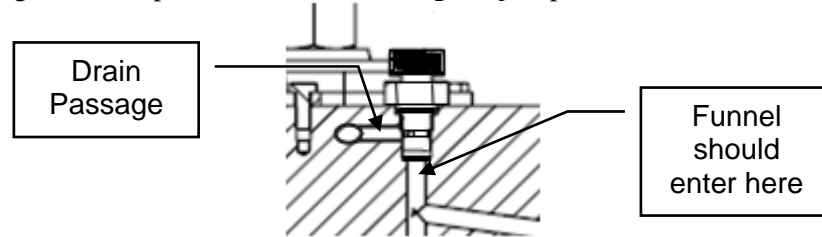

- vacuum to the bottom hole of the PTP socket to draw oil from the makeup valve.
13. Inspect the PTP valve to ensure the sealing o-ring and copper gasket are still in position, and re-install the valve.
  14. In order to fully balance and evacuate the leak detection system, the pump must now run at normal discharge pressure for a period of one hour. This ensures that excess barrier fluid is fully evacuated from the system.
  15. Supply either process fluid, or test fluid (i.e. water) to the suction of the pump and ensure that the discharge system is configured for safe operation. The pump can be started with minimal discharge pressure and then slowly brought up to full pressure, if the system allows for this.
  16. Apply power and start the pump.
  17. Adjust the pump slowly to full (100%) stroke.
  18. Hold down the PTP valve momentarily and observe the smaller tube under the diagnostic cover. If no fluid is coming from this port after 5 minutes, stop the pump and return to step 11. If fluid is present, continue to step 19.
  19. Slowly increase the discharge pressure to full operating pressure, and continue to run the pump for a period of one hour.
  20. During this time, excess barrier fluid will be displaced from the system into the short length of tubing attached to the exit port, balancing the system for proper operation. A small pen mark on the tube can assist in observing this process visually.
  21. After the one-hour startup period, remove the tubing and connection from the housing body and reinstall the pressure gage. Remove the fitting from the fill port and replace with the supplied pipe plug.
  22. Reconnect the alarm switch to the external system if necessary.
  23. The pump and pressure leak-detection system are now properly prepared and ready for normal service. During normal operation, the gauge should roughly indicate 0 (zero) pressure.



**Under certain circumstances, the system may not completely evacuate excess barrier fluid during the procedure as outlined above. In these cases, after several days run time, a small amount of pressure may build in the system. If this occurs, simply loosen the pressure gauge from the switch housing and relieve a small amount of barrier fluid, returning the system to a zero-pressure state.**



**Once this startup procedure is completed, the pressure leak detection system should require no further maintenance.**

## 9.3 PULSAlarm Leak Detection Diaphragm Maintenance



**AFTER DIAPHRAGM FAILURE, PRESSURIZED PROCESS FLUID CAN BE PRESENT IN ANY PART OF THE PULSALARM LEAK DETECTION SYSTEM. TAKE APPROPRIATE PRECAUTIONS AND HANDLE WITH CARE.**

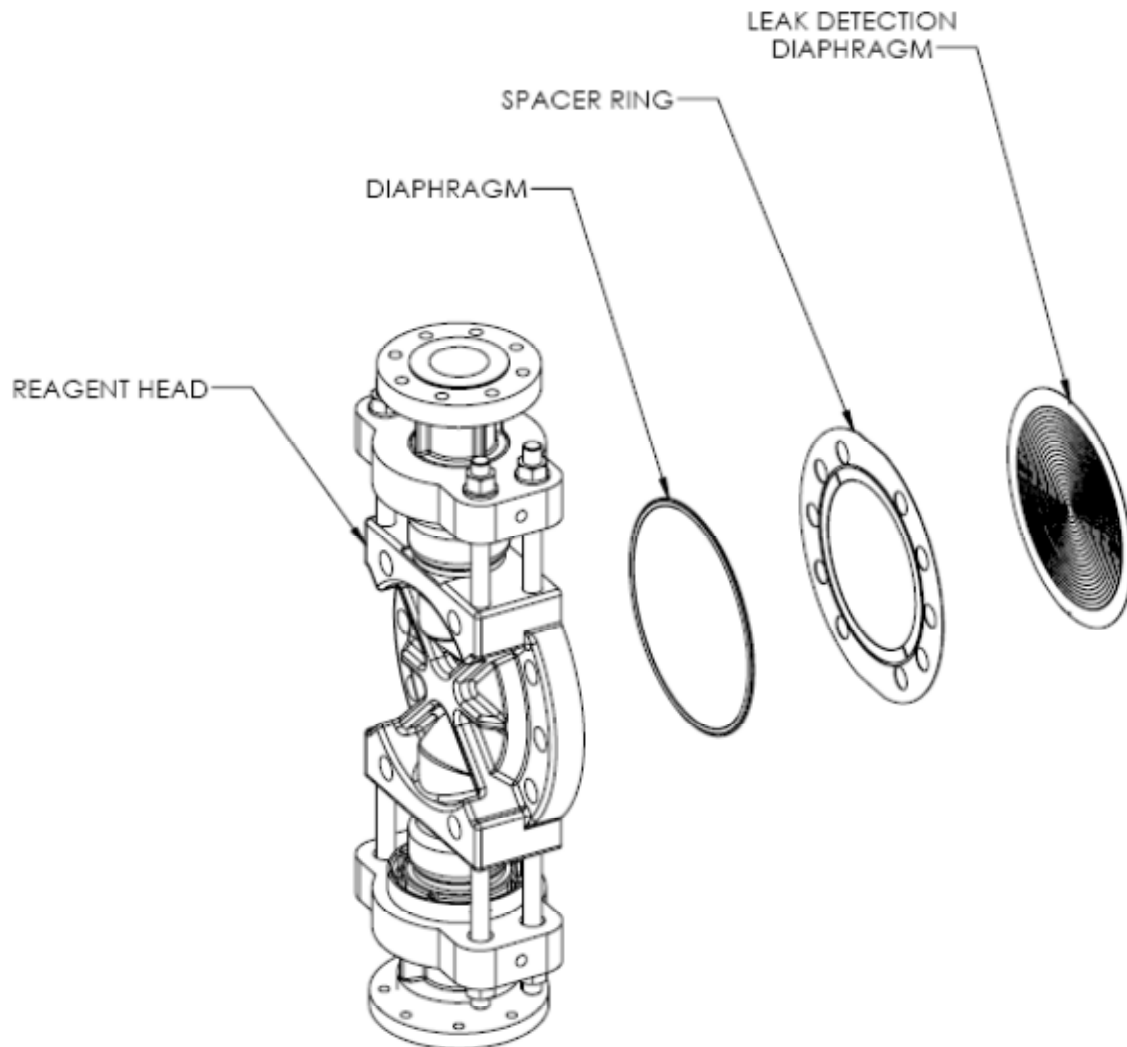

Figure 27

### 9.3.1 Leak Detection Diaphragm Removal



Use the following procedure to remove the Leak Detection Diaphragm:

1. Disconnect the power source to the drive motor (e.g., lockout/tagout the motor disconnect).
2. Relieve all pressure from the piping system, and close the inlet and outlet shutoff valves
3. Take all precautions to prevent environmental and personnel exposure to hazardous materials.
4. Place a suitable container underneath the pump head to catch any liquid leakage.
5. Disconnect process piping and drain any process liquid, following material safety precautions.
6. Remove all but one top reagent head bolt. Oil will leak out between the pump head and reagent head as the bolts are loosened.
7. Tilt the head and pour out any liquids retained by the check valves into a suitable container, continuing to follow safety precautions as appropriate.
8. Remove the alarm switch assembly or pressure gauge from the pump head or reagent head (depending on installation location).
9. Remove the bleed valve assembly and flat gasket from the pump head or reagent head (depending on installation location).
10. Rinse or clean the reagent head with an appropriate material.
11. Remove the diaphragm by running a blunt blade along the periphery and prying it out.

### 9.3.2 Inspection

Remove and inspect the diaphragm assembly. It may have taken a permanent convex/concave set as a result of normal flexure and conformance to the dish-plate. This condition is normal and is not cause for replacement. The diaphragm must be replaced if it is deformed, dimpled, or obviously damaged.



**If the diaphragms have been removed from the spacer ring, the entire assembly should be replaced to ensure proper sealing of its components.**

### 9.3.3 Leak Detection Diaphragm Reinstallation

12. Ensure that the critical sealing areas of diaphragm assembly, reagent head, and pump head are clean and free from debris. Align the diaphragm with the holding pins in the mating seal groove in the pump head and position it into place. Ensure seating of the diaphragm sealing ring into the holding pins is aligned properly.
13. Slide the reagent head into position using the studs and pins as an alignment guide. Tighten in an alternating pattern to ensure an even seating force. Torque to the values recommended in *Appendix III*.
14. Open the needle valve
15. Connect a hand-held vacuum pump or other vacuum source to the vacuum port, which fits 6 mm (1/4 in.) I.D. tubing.
- 16. Follow the same see section 12.4, “Pressure System Set-up and Priming”**
17. If required, test pressure system operation.
18. After diaphragm set-up and priming, the pump is ready to be returned to service.

# 10. Troubleshooting Chart

<u>Difficulty</u>	<u>Probable Cause</u>	<u>Remedy</u>
<b>Pump does not start</b>	<ol style="list-style-type: none"> <li>1. Coupling disconnected</li> <li>2. Faulty power source</li> <li>3. Blown fuse, circuit breaker</li> <li>4. Broken wire</li> <li>5. Wired improperly</li> <li>6. Closed line valves</li> </ol>	Connect coupling Check power source Replace - eliminate overload Locate and repair Check wiring diagram Open valves
<b>No delivery</b>	<ol style="list-style-type: none"> <li>1. Motor not running</li> <li>2. Supply tank empty</li> <li>3. Lines clogged</li> <li>4. Closed line valves</li> <li>5. Check valves held open with solids</li> <li>6. Vapor lock, cavitation</li> <li>7. Prime lost</li> <li>8. Strainer clogged</li> <li>9. Hydraulic system under-primed</li> </ol>	Check power source. Check wiring diagram. Fill tank Clean and flush Open valves Clean - inspect  Increase suction pressure Re-prime, check for leak Remove and clean. Replace screen if necessary Refer to <b><i>Re-priming the Pump</i></b>
<b>Low delivery</b>	<ol style="list-style-type: none"> <li>1. Motor speed too low</li> <li>2. Check valves worn or dirty</li> <li>3. Hydraulic bypass valve operating each stroke</li> <li>4. Calibration system error</li> <li>5. Product viscosity too high</li> <li>6. Product cavitating</li> <li>7. Piston seal worn or damaged by contamination</li> <li>8. Air entrained in Oil (foaming from PTP diagnostic tube)</li> </ol>	Check voltages, frequency, wiring, and Terminal connections. Check nameplate vs. Specifications. Clean, replace if damaged Refer to <b><i>Hydraulic Bypass Valve</i></b>  Evaluate and correct Lower viscosity by increasing product temperature. Increase pump and/or piping size Increase suction pressure. Reduce product temperature Inspect and replace if necessary, refer to <b><i>Piston Seal</i></b> .  Refer to <b><i>Re-priming the Pump</i></b>
<b>Delivery gradually drops</b>	<ol style="list-style-type: none"> <li>1. Check valve leakage</li> <li>2. Leak in suction line</li> <li>3. Strainer fouled</li> <li>4. Product change</li> <li>5. Bypass leakage</li> <li>6. Piston seal worn or damaged by contamination</li> <li>7. Supply tank vent plugged</li> <li>8. Air entrained in Oil (foaming from PTP diagnostic tube)</li> </ol>	Clean, replace if damaged Locate and correct Clean or replace screen Check viscosity Correct for bypass valve leakage Inspect and replace if necessary refer to <b><i>Piston Seal</i></b>  Unplug vent Refer to <b><i>Re-priming the Pump</i></b>
<b>Delivery erratic</b>	<ol style="list-style-type: none"> <li>1. Leak in suction line</li> <li>2. Product cavitating</li> <li>3. Entrained air or gas in product</li> <li>4. Motor speed erratic</li> <li>5. Fouled check valves</li> <li>6. Air entrained in Oil (foaming from PTP diagnostic tube)</li> </ol>	Locate and correct Increase suction pressure Consult factory for suggested venting Check voltage and frequency Clean, replace if necessary Refer to <b><i>Re-priming the Pump</i></b>
<b>Delivery higher than rated</b>	<ol style="list-style-type: none"> <li>1. Suction pressure higher than discharge pressure</li> <li>2. Discharge piping too small</li> <li>3. Back pressure valve set too low</li> <li>4. Back pressure valve leaks</li> </ol>	Install back pressure valve or consult factory for piping recommendations Increase pipe size - install pulsation dampener in discharge line Increase setting Repair, clean, or replace

<b><u>Difficulty</u></b>	<b><u>Probable Cause</u></b>	<b><u>Remedy</u></b>
<b>Pump loses hydraulic oil</b>	<ol style="list-style-type: none"> <li>1. Diaphragm ruptured</li> <li>2. Leaky seal</li> <li>3. Cover gasket leaks</li> <li>4. Eccentric box overfilled</li> </ol>	<p>Replace  Replace  Replace or retighten  Remove excess oil</p>
<b>Air bleeds continuously from PTP (automatic bleed valve)</b>	<ol style="list-style-type: none"> <li>1. Hydraulic oil level low</li> <li>2. Hydraulic bypass valve operating each stroke</li> <li>3. Suction pressure too low</li> <li>4. Oil breakdown. Temperature high</li> <li>5. Plugged hydraulic refill inlet check</li> <li>6. Air entrained in Oil (foaming from PTP diagnostic tube)</li> </ol>	<p>Refill to correct level  Refer to <b><i>Hydraulic Bypass Valve</i></b></p> <p>Increase pressure  Change oil type, consult factory</p> <p>Clean contamination screen</p> <p>Refer to <b><i>Re-priming the Pump</i></b></p>
<b>Noisy gearing, knocking</b>	<ol style="list-style-type: none"> <li>1. Discharge pressure too high</li> <li>2. Water hammer</li> <li>3. Hydraulic bypass valve set too high</li> <li>4. Stroke length at partial setting</li> </ol>	<p>Reduce pressure  Install pulsation dampener  Readjust (refer to <b><i>Hydraulic Bypass Valve</i></b>)</p> <p>Nondestructive knocking sometimes occurs at reduced stroke lengths.</p>
<b>Piping noisy</b>	<ol style="list-style-type: none"> <li>1. Pipe size too small</li> <li>2. Pipe runs too long</li> <li>3. Surge chamber flooded</li> <li>4. No Pulsation Dampener used</li> </ol>	<p>Increase size of piping – install pulsation dampener  Install pulsation dampener in line  Replace with air or inert gas. If a pulsation dampener is installed, replace diaphragm and recharge  Install pulsation dampener</p>
<b>Motor overheats</b>	<ol style="list-style-type: none"> <li>1. Pump overloaded</li> <li>2. High or low voltage</li> <li>3. Loose wire</li> </ol>	<p>Check operating conditions against pump design requirements  Check power source  Trace and correct</p>
<b>Diaphragm Damage</b>	<ol style="list-style-type: none"> <li>1. Diaphragm extruded into pump head holes</li> </ol>	<p>Reduce discharge pressure to pump design limits.  Relieve discharge pressure before stopping pump.  Verify PTP bleeder is bypassing oil. Increase dynamic suction pressure to at least 5 psia. Replace or clean hydraulic performance valve. Replace worn piston seals.</p>

# Appendix I – Piping Calculations

## Suction Head Requirements

All reciprocating metering pumps require a net positive suction head (NPSH<sub>R</sub>). Refer to **Table 1** for the (NPSH<sub>R</sub>) required for *PulsaPro* Series pump models. The NPSH<sub>R</sub> is defined as the pressure required above the absolute vapor pressure of the process fluid at the pumping temperature. This pressure is required at the suction port of the pump throughout the entire pump stroking cycle in order to prevent cavitation of the process fluid within the reagent head. The NPSH<sub>R</sub> is one of the requirements necessary to assure metering accuracy.

NPSH <sub>R</sub>	
English (psi)	3
Metric (bar)	0.35

*Table 1. NPSH<sub>R</sub> values*

The net positive suction head available (NPSH<sub>A</sub>) must be greater than the NPSH<sub>R</sub>. The NPSH<sub>A</sub> of any given system is calculated as follows for comparison to the NPSH<sub>R</sub> as shown in Table 1.

Equation 1 – For fluid viscosity below 50 centipoise.

$$\text{NPSH}_A = P_A \pm P_H - P_V - \left( \frac{L_s R G Q}{C_1 d^2} \right)$$

Equation 2 – For fluid viscosity above 50 centipoise.

$$\text{NPSH}_A = P_A \pm P_H - P_V - \sqrt{\left( \frac{L_s R G Q}{C_1 d^2} \right)^2 + \left( \frac{L_s \mu Q}{C_2 d^4} \right)^2}$$

The variables used in Equations 1 through 5 must be in the units shown in Table 2 for the constants listed below to be used correctly.

Variable	Units Set	
	English	Metric
NPSH	psi	bar
P <sub>A</sub>	psia	bar(a)
P <sub>H</sub>	psi	bar
P <sub>V</sub>	psia	bar(a)
L <sub>S</sub>	feet	meters
R	strokes/min	strokes/min
G	no units	no units
Q	gallons/hr	liters/hr
d	inches	millimeters
μ	centipoise	centipoise
L <sub>D</sub>	feet	meters
P <sub>T</sub>	psi	bar
P <sub>P</sub>	psi	bar
V <sub>P</sub>	feet/sec	meters/sec
C <sub>1</sub>	24,600	640
C <sub>2</sub>	45,700	1.84
C <sub>3</sub>	46.8	0.91

Table 2. Unit sets and constant values for use in Equations 1 through 5.



If piping sizes vary throughout the suction line, different additive values may be used for the pressure losses attributed to the liquid's acceleration and deceleration.



Use the last term of Equation 1 or 2 as many times as needed in the equation to adjust for different lengths/pipe diameters in the suction line. (Everything but the pipe length and diameter will stay the same in the equation.)



All reciprocating metering pumps also require that a minimum absolute pressure, minimum suction head (MSH), be maintained at the pump inlet throughout the pumping cycle to ensure a stable hydraulic system and proper pump operation.

<b>MSH</b>	
English, (psia)	5.0
Metric, (bar(a))	0.35

Table 3. Minimum values for the sum of NPSHA and vapor pressure. (MSH)



The sum of the NPSH<sub>A</sub> and the vapor pressure (P<sub>V</sub>) must be greater than the values shown in Table 3.



## System Back Pressure

The system back pressure must exceed the suction pressure by at least 25 psi (1.7 bar) in order to prevent flow through; however it must not exceed the rated discharge pressure of the pump.

Flow through can be defined as the process liquid flowing from a higher pressure to a lower pressure (downhill pumping), which attributes to pump failure and undesired flow at pump shutdown.

If the system back pressure is not at least 25 psi (1.7 bar) greater than the suction pressure, a back pressure valve must be installed in the discharge piping. To calculate the system's total back pressure use Equation 3 or 4 below.

Equation 3. For fluid viscosity below 50 centipoise.

$$P_T = \left( \frac{L_D R G Q}{C_1 d^2} \right) + P_P \pm P_H$$

Equation 4. For fluid viscosity above 50 centipoise.

$$P_T = \sqrt{\left( \frac{L_D R G Q}{C_1 d^2} \right)^2 + \left( \frac{L_D \mu Q}{C_2 d^4} \right)^2} + P_P \pm P_H$$

## Nomenclature

NPSH <sub>R</sub>	=	Net positive suction head required, [psi, bar]
NPSH <sub>A</sub>	=	Net positive suction head available, [psi, bar]
P <sub>A</sub>	=	Pressure at the surface of the liquid being pumped (atmospheric or supply tank blanket pressure) [psi(a), bar(a)]
P <sub>H</sub>	=	Head pressure above (+) or below (-) the pump centerline, [psi, bar,] (convert from ft or m)
P <sub>V</sub>	=	Absolute vapor pressure at pumping temperature of the process liquid at pump inlet, [psi(a), bar(a)]
L <sub>S</sub>	=	Length of suction piping (actual, not equivalent), [ft, m]
R	=	Pump stroking rate, strokes/min [spm]
G	=	Specific gravity of process liquid, [no units]
Q	=	Pump average flow rate, [gph, lph]
d	=	Internal pipe diameter, [inches, mm]
C <sub>1</sub> , C <sub>2</sub> , C <sub>3</sub>	=	Numeric constants used in Equations 1- 5 [no units]
μ	=	Viscosity of process liquid at pumping temperature, centipoise [cp]
L <sub>D</sub>	=	Length of discharge piping (actual, not equivalent), [ft, m]
P <sub>P</sub>	=	System discharge pressure, [psi(g), bar(g)]
P <sub>T</sub>	=	Peak pump discharge pressure at the discharge port, [psi(g), bar(g)]
V <sub>p</sub>	=	Peak liquid velocity generated by the pump, (suction or discharge) [ft/s, m/s]

# Appendix II – Oil Specifications

## PULSAlube Universal 1HG

<b>MSDS Number:</b>	775465
<b>Appearance:</b>	Clear and bright
<b>Physical Form:</b>	Liquid
<b>Odor:</b>	Petroleum
<b>Odor Threshold:</b>	No data
<b>pH:</b>	Not applicable
<b>Vapor Pressure:</b>	<1 mm Hg
<b>Vapor Density (air=1):</b>	>1
<b>Boiling Point/Range:</b>	No data
<b>Melting/Freezing Point:</b>	<10.4°F / <-12°C
<b>Pour Point:</b>	<10.4°F / <-12°C
<b>Solubility in Water:</b>	Negligible
<b>Partition Coefficient (n-octanol/water) (Kow):</b>	No data
<b>Specific Gravity:</b>	0.86 - 0.90 @ 60°F (15.6°C)
<b>Bulk Density:</b>	7.1 - 7.5 lbs/gal
<b>Viscosity:</b>	5 - 32 cSt @ 100°C; 30 - 500 cSt @ 40°C
<b>Percent Volatile:</b>	Negligible
<b>Evaporation Rate (nBuAc=1):</b>	No data
<b>Flash Point:</b>	>302°F / >150°C
<b>Test Method:</b>	Pensky-Martens Closed Cup (PMCC) ASTM D93, EPA 1010
<b>LEL (vol % in air):</b>	No data
<b>UEL (vol % in air):</b>	No data
<b>Auto-ignition Temperature:</b>	No data

## PULSAlube Ultra 6HGS

<b>MSDS Number:</b>	98E374
<b>Physical State:</b>	Liquid
<b>Color:</b>	Orange
<b>Odor:</b>	Characteristic
<b>Odor Threshold:</b>	N/D
<b>Relative Density (at 15 C):</b>	0.857
<b>Flash Point [Method]:</b>	>210C (410F) [ ASTM D-92]
<b>Flammable Limits</b>	
<b>(Approximate volume % in air):</b>	LEL: 0.9 UEL: 7.0
<b>Auto ignition Temperature:</b>	N/D
<b>Boiling Point / Range:</b>	> 260C (500F)
<b>Vapor Density (Air = 1):</b>	> 2 at 101 kPa
<b>Vapor Pressure:</b>	< 0.013 kPa (0.1 mm Hg) at 20 C
<b>Evaporation Rate (n-butyl acetate = 1):</b>	N/D
<b>pH:</b>	N/A
<b>Log Pow (n-Octanol/Water Partition Coefficient):</b>	> 3.5
<b>Solubility in Water:</b>	Negligible
<b>Viscosity:</b>	68 cSt (68 mm <sup>2</sup> /sec) at 40 C   10.9 cSt (10.9 mm <sup>2</sup> /sec) at 100C
<b>Oxidizing Properties:</b>	See Hazards Identification Section.
<b>Freezing Point:</b>	N/D
<b>Melting Point:</b>	N/A
<b>Pour Point:</b>	-45°C (-49°F)

# Appendix III – Bolt Torque Recommendations/Nozzle Loads

## Reagent Head and Tie-Bar

REAGENT HEAD SIZE	RH PART NUMBER	PISTON SIZE (in)	DESCRIPTION	TORQUE FT-LBS / N-m
12.5	NP160085-316	5.50	REAGENT HEAD, NUT, M30-3.5	310 / 420
			TIE BAR, NUT, M24-3.0	95 / 129
10.5	NP160084-316	4.00	REAGENT HEAD, NUT, M30-3.5	410 / 555
			TIE BAR, NUT, M24-3.0	100 / 135
8.5	NP160083-316	2.00, 2.50, 3.00	REAGENT HEAD, NUT, M30-3.5	970 / 1314
			TIE BAR, NUT, M30-3.5	315 / 427
6.0	NP160082-316	1.75	REAGENT HEAD, NUT, M24-3.0	515 / 697
			TIE BAR, NUT, M30-3.5	405 / 548



**NOTE**

When torquing the bolts, make sure you start with bolts equally hand tight. Then torque to one half the specified rating following the bolt patterns below. Once you have completed the first pass, then torque to the final rating.

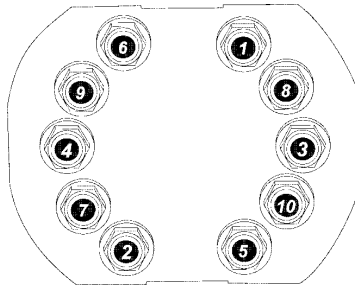

## Pump Head Bolts

Piston Size	Bolt Size	Torque Ft. Lbs / N-m
1.75	M30-3.5	350 / 474
2.0	M30-3.5	350 / 474
2.5	M30-3.5	350 / 474
3.0	M30-3.5	350 / 474
4.0	M30-3.5	350 / 474
5.5	M30-3.5	350 / 474

# Nozzle Loads

Load Type - Direction	Load	Load
Force - X	150 lb	667 N
Force - Y	150 lb	667 N
Force - Z	250 lb	1,112 N
Moment	1,600 in-lb	181 N-M

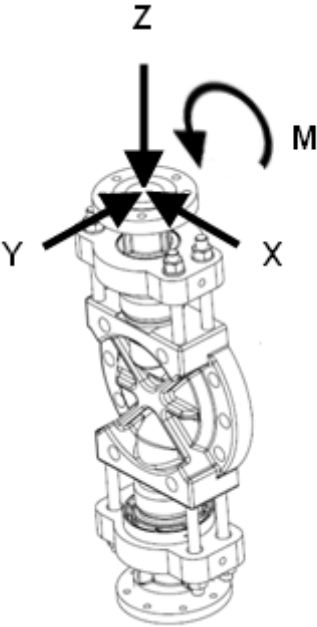

# Appendix IV Dimensional Drawings

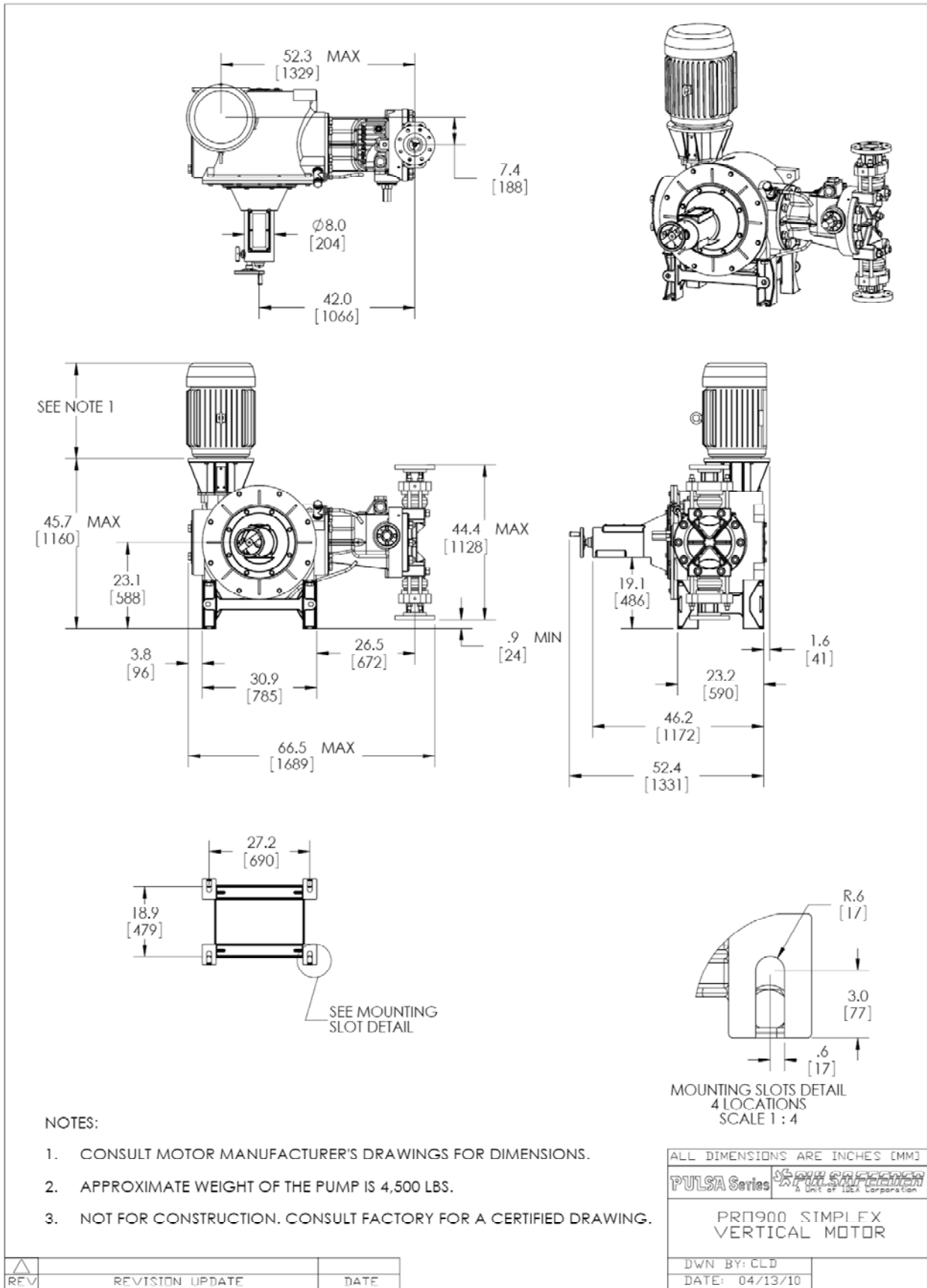

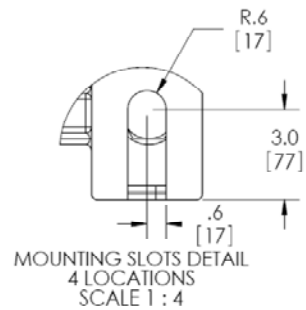
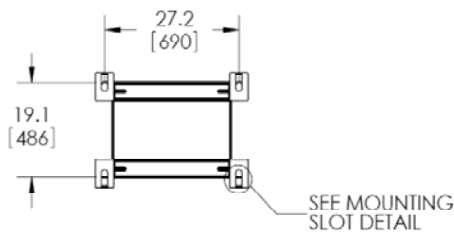
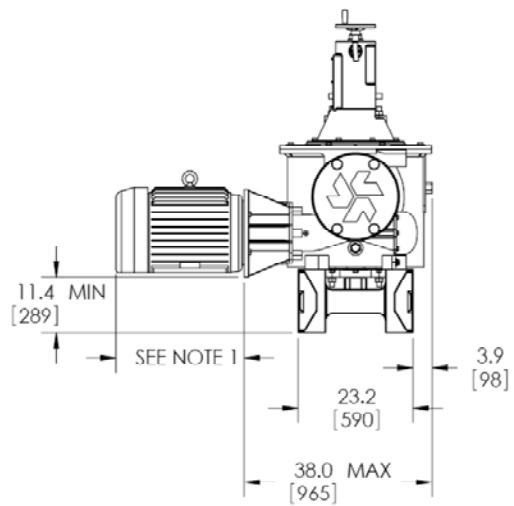
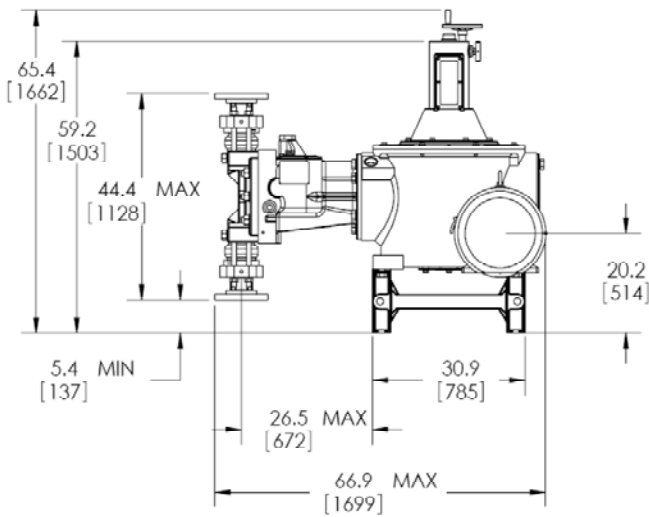
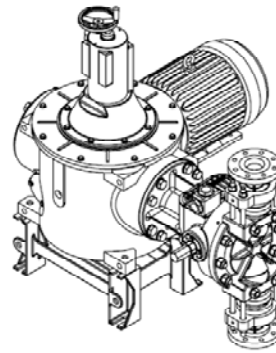
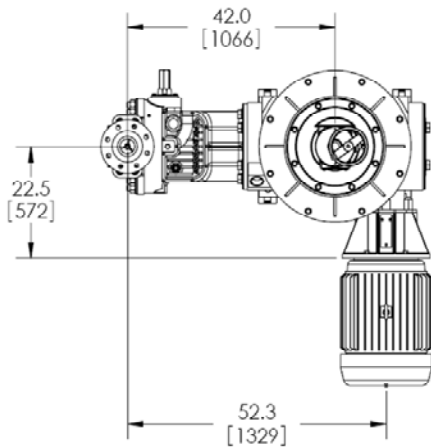

NOTES:

1. CONSULT MOTOR MANUFACTURER'S DRAWINGS FOR DIMENSIONS.
2. APPROXIMATE WEIGHT OF THE PUMP IS 4,500 LBS.
3. NOT FOR CONSTRUCTION. CONSULT FACTORY FOR A CERTIFIED DRAWING.

REV	REVISION	UPDATE	DATE

ALL DIMENSIONS ARE INCHES [MM]

PULSA Series  A UNIT OF IDEXX CORPORATION

PRO900 SIMPLEX  
HORIZONTAL MOTOR

DWN BY: CLD  
DATE: 04/13/10

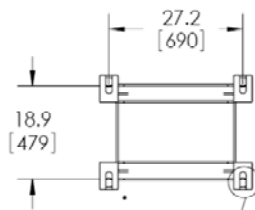
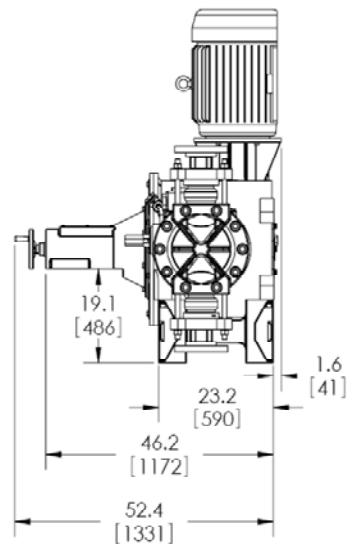
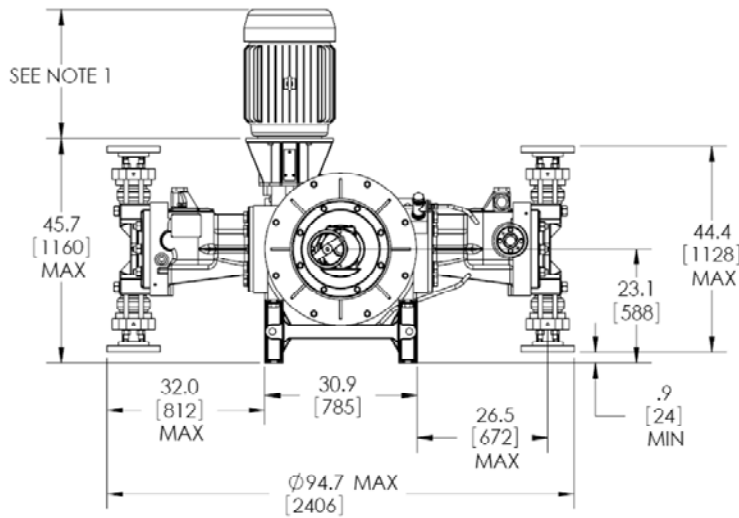
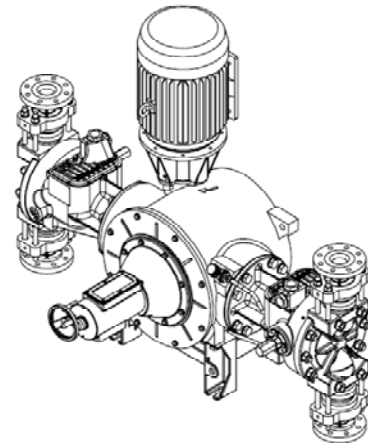
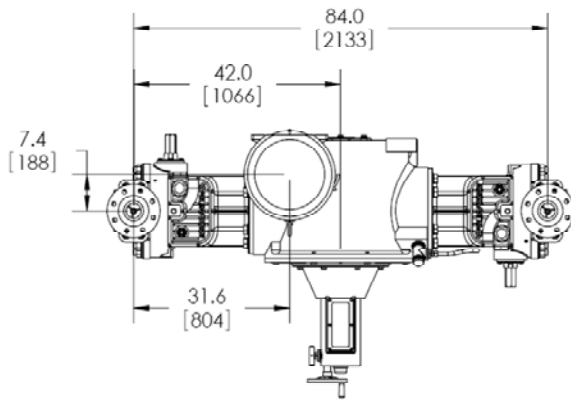

SEE MOUNTING  
SLOT DETAIL

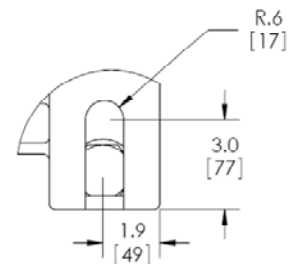

MOUNTING SLOTS DETAIL  
4 LOCATIONS  
SCALE 1 : 4

NOTES:

1. CONSULT MOTOR MANUFACTURER'S DRAWINGS FOR DIMENSIONS.
2. APPROXIMATE WEIGHT OF THE PUMP IS 5,500 LBS.
3. NOT FOR CONSTRUCTION. CONSULT FACTORY FOR A CERTIFIED DRAWING.

ALL DIMENSIONS ARE INCHES [MM]

PULSA Series *Flow Control*  
A UNIT OF IDEX CORPORATION

PR0900  
DUPLEX

DWN BY: CLD  
DATE: 04/13/10

REV	REVISION UPDATE	DATE

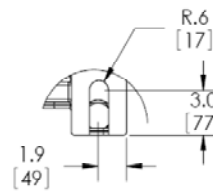
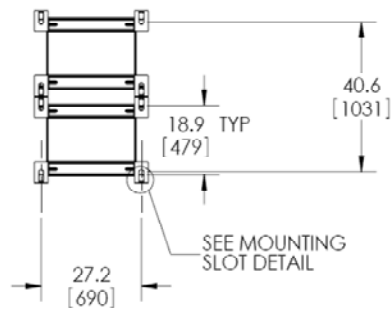
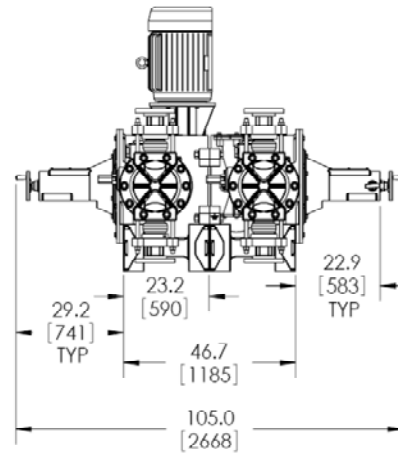
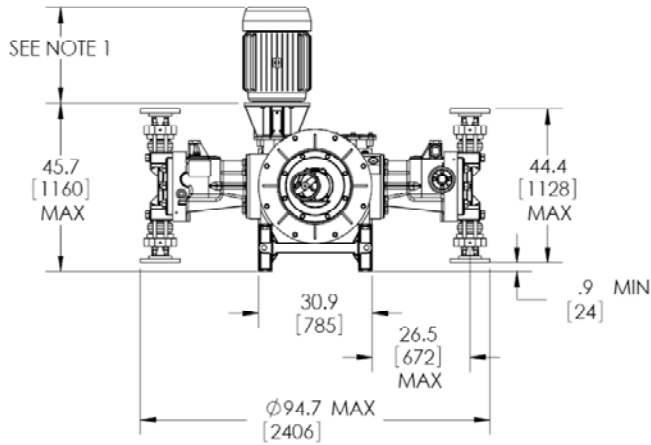
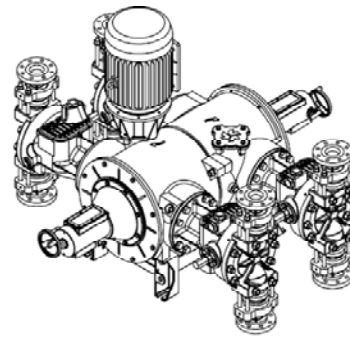
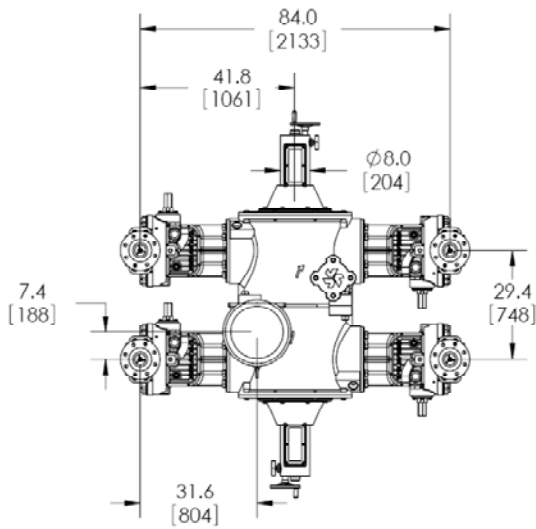

MOUNTING SLOT DETAIL  
8 LOCATIONS  
SCALE 1 : 8

NOTES:

1. CONSULT MOTOR MANUFACTURER'S DRAWINGS FOR DIMENSIONS.
2. APPROXIMATE WEIGHT OF THE PUMP IS 10.000 LBS.
3. NOT FOR CONSTRUCTION. CONSULT FACTORY FOR A CERTIFIED DRAWING.

REV	REVISION UPDATE	DATE

ALL DIMENSIONS ARE INCHES [MM]	
PULSA Series	<b>PULSA PUMPS</b> A UNIT OF IDEX CORPORATION
PR900 QUAD	
DWN BY: CLD	
DATE: 04/13/10	





# Appendix V EC Declaration of Conformance



Pulsafeeder, Inc.  
2883 Brighton-Henrietta Town Line Road  
Rochester, NY 14623  
www.pulsa.com



Agriculture  
Chemical Processing  
Fuels & Energy  
Sanitary  
Water

## CE DECLARATION OF CONFORMANCE

**Manufacturer:** Pulsafeeder Inc., Engineered Pump Operations  
2883 Brighton-Henrietta Townline Road  
Rochester, New York 14623 USA  
Tel: 1 (585) 292-8000 – Fax: 1 (585) 424-5619

**Models Covered:**

Pulsa Series Metering Pumps:	340, R1, 680, 880, 7120, 7440, 7660, 8480, 9490
Pulsar Series Metering Pumps:	25H, 55H, Pulsar HypoPump, Shadow, Shadow HypoPump, Series M
PulsaPro Series Metering Pumps:	PulsaPro 900

We, Pulsafeeder, Inc., Rochester, New York, United States of America, declare under our sole responsibility that the products relevant to this declaration comply with the following directives and subsequent modifications:

**EU Directive(s):**  
2006/42/EC – Machine Safety Directive; formerly known as 98/37/EC, formerly known as 91/368/EEC  
97/23/EC – Pressure Equipment Directive

**Harmonized Standard(s):**  
BS EN ISO 12100:2010  
EN ISO 12100-1:2003; formerly known as EN 292-1  
EN ISO 12100-2:2003; formerly known as EN 292-2

The technical construction file is maintained at:  
2883 Brighton-Henrietta Townline Road, Rochester, New York 14623, USA

Date of issue: March 16<sup>th</sup>, 2012  
Place of issue: 2883 Brighton-Henrietta Townline Road  
Rochester, New York 14623, USA

Issued By:

**Stephen Muscarella**  
*Director of Engineering, Pulsafeeder, Inc.*

Responsible for Technical File Acquisition:

**Stefano Copelli**  
*Manager of Engineering, OBL s.r.l.*  
OBL s.r.l. - Via Kennedy, 12 - 20090 Segrate – MILANO, ITALY  
Tel. +39 02 26919.1 – Fax +39 02 2133893

# PulsaPro Control



# Rotork Actuator

## Installation, Operation & Maintenance Addendum

USER NOTE: This addendum serves as additional information for Pulsafeeders PulsaPro 900 supplied with Rotork Model IQ Series Automatic stroke control. You must also reference the latest revision of the complete PulsaPro pump IOM and Rotork's IOM for critical safety and operational information.

## FACTORY SERVICE POLICY

If you are experiencing a problem with your Pulsafeeder supplied pump controller, first review to the PulsaPro 900 IOM, this addendum and the Rotork IQ Series IOM E170E3. If the problem is not covered or cannot be solved, please contact your local PULSA Series Sales Representative or our Technical Service Department at (585) 292-8000 for further assistance.

If the problem is directly related to the Rotork controller you will be directed to contact Rotork service support at [service@rotork.com](mailto:service@rotork.com) or [www.rotork.com](http://www.rotork.com).

UK head office  
Rotork Controls Limited  
telephone Bath 01225 733200  
telefax 01225 333467  
email [mail@rotork.co.uk](mailto:mail@rotork.co.uk)

USA head office  
Rotork Controls Inc  
telephone Rochester (585) 247 2304  
telefax (585) 247 2308  
email [info@rotork.com](mailto:info@rotork.com)

Trained individuals are available to diagnose your problem and arrange a solution. Solutions may include purchasing a replacement unit or returning the pump or components to the factory for inspection and repair. All returns require a Return Material Authorization (R.M.A.) number to be issued by Pulsafeeder or Rotork.

Certain components may be purchased for replacement. Parts purchased to correct a warranty issue may be credited after examination of the original parts by Pulsafeeder or Rotork personnel. Parts returned for warranty consideration that test satisfactorily, will be sent back to the originator freight collect.

**Any field modifications will void the product warranty. Out-of-warranty repairs will be subject to standard bench fees and testing costs associated with replacement components.**

### Notice:

1. Information and specifications in this document are subject to change without notice.

Trademarks:   
Produced in the UK by Rotork Controls Limited.POWTG0607

The name Rotork is a registered trademark. Rotork recognizes all registered trademarks. Published and

# 1. Scope of Supply

This addendum covers the installation of a Rotork series IQ controller supplied with PulsaPro 900 series pump. This mounting installation information is not covered in the Rotork IQ Installation and Maintenance Instruction manual E170E3.

## 2. General Safety

This controller assembly was designed for operation solely with the Pulsafeeder PulsaPro 900 pump. Using this unit for any other application or on any other piece of equipment is considered un-safe and voids all certification markings and warranties.

### 2.1 Explosive Atmosphere Safety



**Explosion Hazard -- Do not perform installation or maintenance of any kind on this device while circuit is live and/or the area is known to be hazardous.**

### 2.2 Electrical Safety

Improper application and use of the switch assembly can be hazardous. You are solely responsible for its use.

The electrical installation must conform to all relevant electrical codes. Installation and electrical maintenance must be performed by a qualified electrician. Before installing or servicing this device please refer to Rotork IOM E170E3 which can be found in the pump document packet or at [www.rotork.com](http://www.rotork.com).

### 2.3 Hydraulic Safety

Thoroughly review and adhere to the contents of the latest version of the PulsaPro 900 Installation, Operation, and Maintenance (IOM) manual for hydraulic installation of your PulsaPro 900 metering pump.

## 3. Mounting of Pump Controller



During assembly of the stroke control unit to pump, NO adjustment should be made to the stroke controller or pump input shaft...Doing so will alter the zero point of the pump and will cause damage upon startup.



The Stroke Control unit comes from the factory with preset parameters for limits of zero and one hundred percent stroke settings. These parameters must not be alerted in any way or damage will occur to the stroke adjust components. Refer to the Rotork IOM before any additional programming is done.

- 3.1 The stroke control unit is supplied with 2 sealing O-rings; these o-rings must be installed prior to mounting of the stroke control unit. Refer to illustration below. **See Figure A**

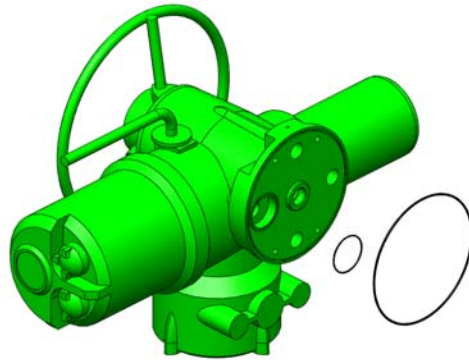
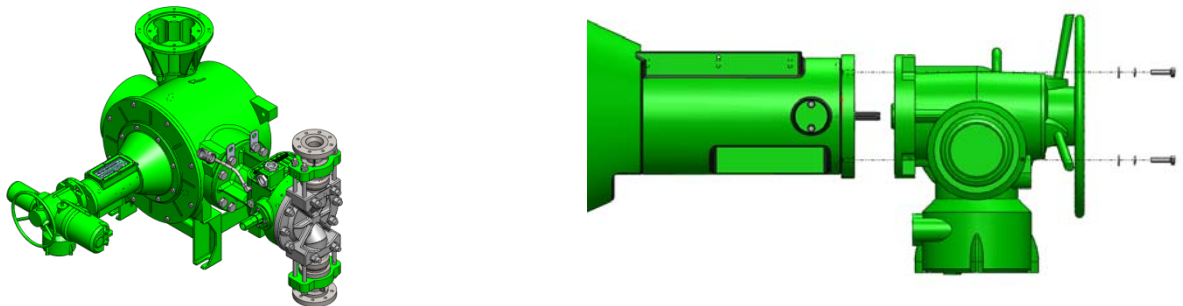

**Figure A**

- 3.2 Remove Red plastic shipping cap from the pumps stroke adjust housing matting face prior trying to bolt the unit into place.

**3.3 Reference Figure B:**

Properly supporting the stroke control unit lift the stroke control unit into place so the splined pump input shift is lined up with the female spline in the controller unit. Using caution to avoid putting stress or any excessive loading on the shaft, slide unit into place until the 2 mounting faces are flush or mated. Install the Qty 4 M8 bolts with flat washers and lock washers. Torque bolts to 16 ft lbs / 70 nm.



**Figure B**

Installation of the stroke controller to pump is now completed. Please refer to Rotork's IOM E170E3 for wiring and setup of additional features such as 4-20 Ma input/output, alarms and other IO that you might require.



When conducting the final wiring or setup of additional IO features, **DON'T ALTER ANY POSITION SETTINGS OR PRESET FACTORY TORQUE LIMITS.** Doing so will cause damage to the stroke control unit.



A Unit of IDEX Corporation



Engineered Pump Operations  
2883 Brighton-Henrietta Townline Road  
Rochester, New York 14623  
Telephone: (585) 292-8000 Fax: (585) 424-5619  
<http://www.pulsa.com> [pulsa@idexcorp.com](mailto:pulsa@idexcorp.com)



An ISO 9001 and 14001 Certified Company

Pulsafeeder, Inc.  
2883 Brighton-Henrietta Town Line Road  
Rochester, NY 14623  
Email: [pulsa@idexcorp.com](mailto:pulsa@idexcorp.com)  
Telephone: ++1 (585) 292-8000  
Fax: ++1 (585) 424-5619  
[Pulsafeeder.com](http://Pulsafeeder.com)