

# AVP

## Boiler Blowdown Valve Packages

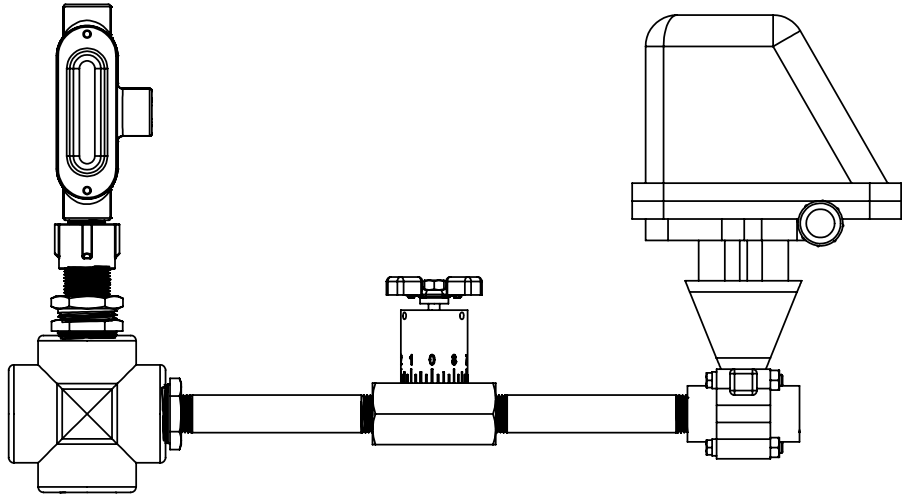

AVP valve packages take the guess work out of blowdown plumbing configurations. AVP's are factory pre-assembled to meet your boiler application pressure requirements complete with the probe cross (probe not included) and correct pipe lengths between components. Make installations even easier using prefabricated option P and we will pre-wire and mount your controller.

**Model Number** \_\_\_\_\_

AVP- \_\_\_\_\_ - \_\_\_\_\_

**Electric Blowdown Valve** \_\_\_\_\_

- 30** = MBWB-½ motorized ball valve SS, 360° actuator, 450 psi max
- 40** = MBWA-½ motorized ball valve SS, 90° actuator, 450 psi max
- 60** = SOB-½ brass solenoid valve, 0-140 psi max

**Flow Restricting Device** \_\_\_\_\_

- 00** = AOU-1 orifice union with 4 plates, 1000 psi
- 30** = NFC-½ needle flow control valve, 5000 psi max

**Optional Features** \_\_\_\_\_

- A** = Adds second flow restricting device for continuous sampling
- C** = ¾" probe tee instead of 1"
- F** = Add a ¾" flush ball valve on bottom of probe cross
- Y** = Add a ½" Y strainer with flush valve before blowdown valve
- Y1** = Add ¾" Y-strainer with flush valve before blowdown valve
- P** = Mount AVP and separately ordered controller onto poly board and pre-wire
- P1** = Mount AVP and separately ordered controller & sample cooler onto poly board & pre-wire

**Note:** Change 2nd digit of code to 1 for ¾" or 2 for 1" connection, add individual valve price difference: AVP-61-11

## Specifications

The specifications of your AVP will depend on the individual items selected. The total shipping weight will be the total of the two valves selected plus approximately 9 pounds (Option P will be more).

**Note:** Older style VP valve packages are not pre-assembled but use components covered in the specifications listed below.

### MBWB

Max Fluid Temp. .... 459°F  
 Max Boiler Pressure ..... 450 PSIG  
 Valve Body..... Carbon Steel  
 Ball & Stem..... 316 SS  
 Seals..... Teflon  
 Shipping Weight ..... 9 lbs.  
 Actuator Ambient Max. .... 150°F  
 Standard Electrical ..... 120 VAC 2.3 Amp  
 Sizes Available ..... 1/2" & 3/4"



### MBWA

Max Fluid Temp. .... 459°F  
 Max Boiler Pressure ..... 450 PSIG  
 Valve Body..... Carbon Steel  
 Ball & Stem..... 316 SS  
 Seals..... Teflon  
 Shipping Weight ..... 12 lbs.  
 Actuator Ambient Max. .... 150°F  
 Standard Electrical ..... 120 VAC 2.3 Amp  
 Sizes Available ..... 1/2" & 3/4"



### SGB

Max Fluid Temp. .... 350°F  
 Max Boiler Pressure ..... 13-140 PSIG  
 Valve Body..... Brass  
 Seals..... Teflon  
 Shipping Weight ..... 3 lbs.  
 Standard Electrical ..... 120 VAC  
 Sizes Available ..... 1/2" & 3/4"



### SOB

Max Fluid Temp. .... 356°F  
 Max Boiler Pressure ..... 140 PSIG  
 Valve Body..... Brass  
 Seals..... Teflon  
 Shipping Weight ..... 3 lbs.  
 Standard Electrical ..... 120 VAC  
 Sizes Available ..... 1/2" & 3/4"



### AOU-1

Max Fluid Temp. .... 500°F  
 Max Boiler Pressure ..... 1000 PSIG  
 Body ..... Carbon Steel  
 Plates..... 316 Stainless Steel  
 Orifice Sizes ..... 1/8", 3/16", 1/4", 5/16"  
 Shipping Weight ..... 3 lbs.  
 Sizes Available ..... 3/4" & 1"

### NFC

Max Fluid Temp ..... 600°F  
 Max Boiler Pressure ..... 5,000 PSIG  
 Body ..... Carbon Steel  
 Stem ..... 304 Stainless Steel  
 Shipping Weight ..... 4 lbs.  
 Sizes Available ..... 1/2" & 3/4"



## Boiler Blowdown Requirement Calculation

A boiler's blowdown configuration (timed or continuous) is determined by the blowdown requirement in pounds of steam per hour. Using the following information:

1. Boiler steam output H.P. x 34.5 = steam output/hour
2. Make-up of water in ponds/hour based on percentage of return condensate
3. Cycles of conductivity concentration

$$\text{Steam output/hr} \times \left( 1 - \frac{\% \text{ Condensate}}{100\%} \right) = \text{Make-up water (lbs/hr).}$$

$$\text{Make-up} \times \left( \frac{1}{\text{Cycles} - 1} \right) = \text{Blowdown required (lbs/hr).}$$

Boilers under 5,000 lbs/hr blowdown use timed sampling. If over 5,000 lbs/hr, continuous sampling is recommended.

**Get the Advantage**



4700 Harold-Abitz Dr  
 Muskogee, OK 74403  
 918-686-6211 Phone  
 888-686-6212 Fax  
[www.advantagecontrols.com](http://www.advantagecontrols.com)