

The HYDRACONE R1 is a reciprocating, single acting, combination piston, hydraulically actuated diaphragm, metering pump. The conical shaped diaphragm expands by controlled displacement of hydraulic oil on the discharge stroke. The diaphragm retracts from its own elasticity during the suction stroke. It is designed for negative suction pressure systems and is suitable for applications containing solids and abrasives or highly viscous fluids.

### Key Features

- High performance Hypalon<sup>®</sup> or Viton<sup>®</sup> diaphragms for superior chemical resistance
- Reagent heads are available in 316SS, Alloy 20, or FPP.
- Special high-quality Dynalloy<sup>®</sup> bronze worm gears for longer life.
- Free acting, component-style guided ball valves promote pump accuracy and long service life and can be easily disassembled for maintenance and cleaning
- Operates successfully with suction pressures as low as 3 psia
- The pump will operate dry indefinitely without damage due to interruption of process fluid supply
- Automatic hydraulic by-pass valve relieves oil under excess pressure
- Totally enclosed weather-resistant gearbox
- All moving parts are positively oil-flooded, assuring perfect lubrication and extra protection against corrosion
- Manual control stroke length is fully adjustable from 0% to 100% While pump is operating or idle
- External stroke adjustment with highly visible micrometer reader to +/-0.5% resolution

### Control Options

#### MPC Vector

The MPC VECTOR is an advanced pump controller that is physically separated from the pump's enclosure. Its purpose is to precisely adjust output flow of a process media by means of pump motor speed control, and is designed for a wide variety of control applications.



### Operating Benefits

- Delivers accuracy within  $\pm 1\%$  of pump rated capacity
- Can be used for batch or continuous process requirements
- Flow through path is good for high viscosities and slurries
- Flows up to 25.6 GPH (97 LPH), and pressures up to 1200 psi (83 bar)
- Maximum suction lift 24" of mercury



### Aftermarket & Accessory Offerings

- KOPkit<sup>®</sup>
- Cal Columns
- Strainer
- Pressure Relief Valves
- Back Pressure Valves
- Pulsation Dampeners
- Gauges



# PULSA Series® R1

## Specifications and Model Selection

RATED FLOW, AT RATED PRESSURE GPH (LPH)				RATED PRESSURE PSI (Bar)	PISTON SIZE (inches)	Connection INLET/OUTLET FNPT (inches)
50 Hz Flow		60 Hz Flow				
58 SPM	116 SPM	58 SPM	116SPM			
1.54 (5.84)	3.3 (12.3)	1.85 (7)	3.9 (14.8)	1200 (83)	0.779	½ "
2.3 (8.8)	5.3 (20)	2.8 (10.6)	6.3 (24)	800 (55)	0.834	
5.8 (21.8)	12.5 (47)	6.9 (26)	15.0 (57)	410 (28)	1.000	
10.4 (39.4)	21.3 (81)	12.5 (47)	25.6 (97)	230 (16)	1.187	

### Engineering Data

- Hypalon cone is standard, Viton cone is optional
- Full motion hydraulic bypass operation
- Metal liquid ends have PTFE o-rings with 316SS or Alloy 20 wetends; Plastic liquid ends, o-rings match Cone, available in PP or PVDF
- Accuracies to 1% of rated capacity
- Viscosities to 1,000 cps
- Min suction pressure 3 psia
- Max suction lift 24" of mercury
- Manual stroke length 0-100%
- Temperature from 40°F (4.4°C) to 150°F (65°C)
- Standard motor is ¼ HP. NEMA 56C. 110/220-115/230

### Custom Engineered Designs

- Optional Flanges
- Alternate wetend materials

### Dimensions

PULSA R1	L	H	W	Approx. Shipping Weight
Inches	15	17	11	45 lbs.
Centimeters	38.1	43.2	27.9	20.4 kg

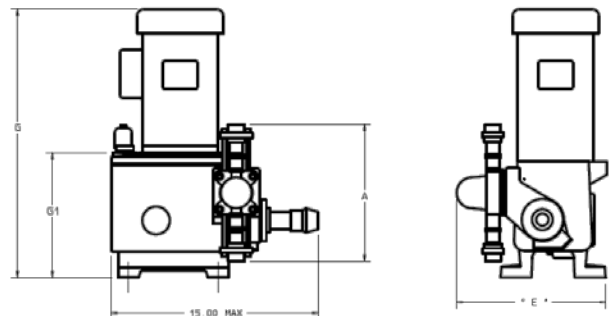

[pulsafeeder.com](http://pulsafeeder.com)



2883 Brighton Henrietta TL Rd  
Rochester, NY 14623  
Phone: ++1(585) 292-8000  
Fax: ++1 (585) 424-5619

An ISO 9001 and ISO 14001 Certified Company



HYD002-J11