

The *Chem-Tech* PRIME PERFORMANCE Series pumps have a specially designed degassing valve system for applications using off-gassing chemicals like sodium hypochlorite. Built upon motorized-diaphragm technology, the *PRIME PERFORMANCE Series* delivers dependable performance, extended longevity and consistent metering over long periods of time in a compact form.

A top-mounted, one-way vent valve assembly evacuates gas bubbles from the pump head, providing for **reliable** operation.

Simple, adjustable stroke system with locking lever provide **easy** flow rate control and turndown.

The compact, injection-molded housing and PVC pump head offer both **affordability** and chemical resistance. The industrial grade, low-stress diaphragm provides **long life**, even in the harshest conditions or longest duty cycles.

**PP100 Models** - Perfect for off-gassing applications where economical, consistent performance is required. Capable of a wide range of flows, from less than 15 USGPD (2.34 lph) up to 30 USGPD (4.72 lph) and pressures up to 100 PSIG (7 BAR).

**PP150 Models** - Built upon the same solid platform as the 100 Models, these units are capable of higher flow rates. With a range offering up to 100 USGPD (15.76 lph), the Series 150 can meet the demands of larger applications. Maximum pressure is 60 PSIG (4.2 BAR).

## Features

- Degassing Pump Head.
- Guided Quad Check Valve System.
- Feed Rate Control.

## Controls



### Feed Rate Control

- Adjustable Feed Rate.

## Operating Benefits

- Reliable metering performance.
- Sealed gear train.
- Easy tube change-out.
- Self priming.
- Chemical resistant materials.
- Simple installation.



## Aftermarket

- KOPkits
- Gauges
- Dampeners
- Pressure Relief Valves
- Tanks
- Pre-Engineered Systems
- Process Controllers (PULSAblue, MicroVision)



Standard Agency Listings			
Model	ETL	ETLsan	CE
All 60Hz	X	X	
All 50Hz			X
Contact factory for alternate listings			

## Specifications and Model Selection

MODELS:	
X015	= 15 gpd (2.34 lph) max pres.: 100 PSI (7 BAR)
X024	= 24 gpd (3.78 lph) max pres.: 100 PSI (7 BAR)
X030	= 30 gpd (4.72 lph) max pres.: 100 PSI (7 BAR)
X068	= 68 gpd (10.72 lph) max pres.: 60 PSI (4 BAR)
X100	= 100 gpd (15.76 lph) max pres.: 60 PSI (4 BAR)

## Engineering Data

<b>Pump Head Materials Available:</b>	PVC
<b>Diaphragm:</b>	PTFE-faced CSPE-backed Viton
<b>Check Valves Materials Available:</b>	CSPE
<b>Seats/O-Rings:</b>	Viton
<b>Balls:</b>	Ceramic
<b>Fittings Materials Available:</b>	PVC
<b>Injection Valve &amp; Foot Valve Assy:</b>	Same as fitting and check valve selected
<b>Tubing:</b>	Clear PVC White PE Black PE
<b>Viscosity Max CPS:</b>	20 CPS
<b>Power Input:</b>	115 VAC/60 HZ, 230 VAC/50 HZ 230 VAC/60 HZ
<b>Temperature Limitations:</b>	125°F / 51°C max.
<b>Shipping Weight:</b>	8 lbs. / 3.63kg.

Specifications subject to change without notice.

Important: Material Code - GFPL=Glass-filled Polypropylene, PVC=Polyvinyl Chloride, PE=Polyethylene, PVDF=Polyvinylidene Fluoride, CSPE=Generic formulation of Hypalon, a registered trademark of E.I. DuPont Company. Viton is a registered trademark of E.I. DuPont Company. PVC wetted end recommended for sodium hypochlorite.

## Integrated Tank Systems



### Integrated Tank Systems

Pulsafeeder's ITS System is a completely integrated tank system constructed of high density UV resistant polyethylene (PE) with a 15 gallon capacity. This tank system is translucent with 5 gallon increments and the tank's low level indicator allows visual monitoring of chemicals without opening the tank. The tight fitting child proof lid keeps the chemical free of contaminants and protects the surrounding area from chemical fumes.

The ITS System also allows for easy access to the liquid end and control panel of the mounted pump.

A system consists of a chemical tank with lid and bulkhead fittings: a liquid level indicator float assemble and feeder mounting hardware.

## Dimensions All dimensions expressed as inches (mm)

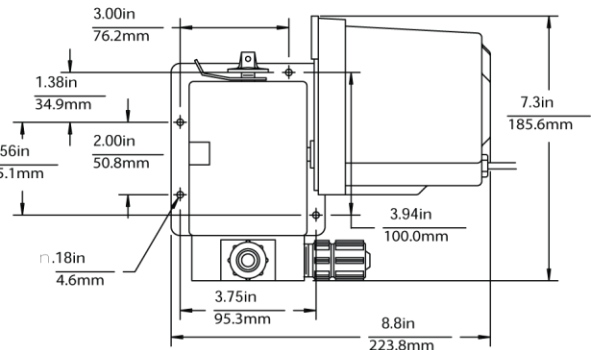
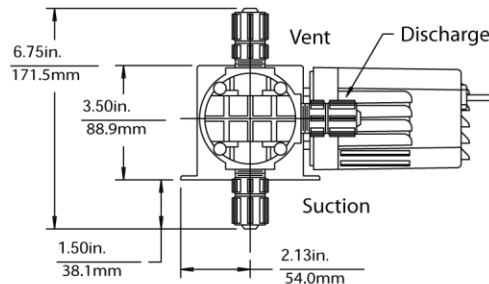
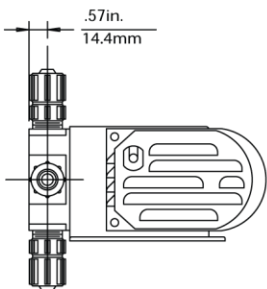

[pulsafeeder.com](http://pulsafeeder.com)



27101 Airport Rd  
Punta Gorda, FL 33982  
Phone: ++1(941) 575-3800  
Fax: ++1(941) 575-4085

An ISO 9001 and ISO 14001 Certified Company



CTI008 I12