

Series MP2-R Peristaltic Pump

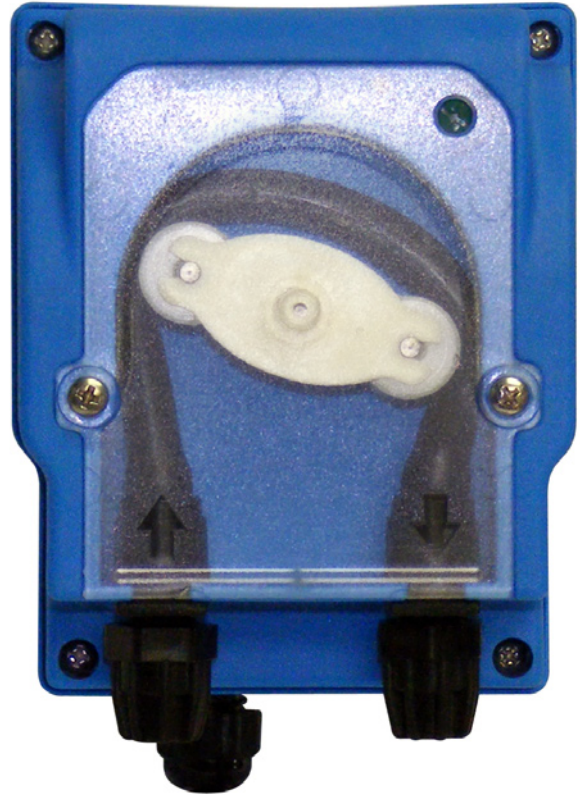

Key Features

- Peristaltic Operation
- Adjustable Speed
- Small Dimension
- Easy Installation
- Minimal Maintenance
- IP 65 Protection
- Automatic Priming
- Wall Mount Bracket

Application

- Cooling Towers
- Chemical Industries
- Medical Industries
- Laboratories and Analysis
- Food Industries
- Warewash
- Disinfection
- Swimming Pools

Materials / Accessories

Liquid Ends Material

Component	Standard
Roller Tube	EPDM
Fittings	PP
Foot Filter	AISI 316
Injection Valve	AISI 316 - Viton
Discharge Tube	PE 4 x 6 mm (0.15" x 0.23")
Suction Tube	Clear PVC 4 x 6 mm (0.15" x 0.23")

Included Accessories

Component
Injection Valve
Injection Tube
Suction Tube
Foot Valve Strainer

Specifications

Electrical

- **Supply:** 100-240 VAC, 3.5 Watt

Enclosure

- PP box reinforced 30% glass fiber
- Polycarbonate front panel
- IP 65 Rating

Shipping Weight: Approx. 1.54 lbs. (0.7 kg)

Dimensions: Width: 3.33" (84.5 mm)
 Height: 4.92" (125 mm)
 Depth: 4.15" (105.5 mm)

Technical Characteristics

Model	l/h	gal/h	ml/min	oz/min	bar	psi	rpm	Roller Tube	Tube Diameter
MP2-R 1/3	1	0.26	16.6	0.56	3	43.5	30	EPDM	3.2 x 6.4 mm (0.12" x 0.25")

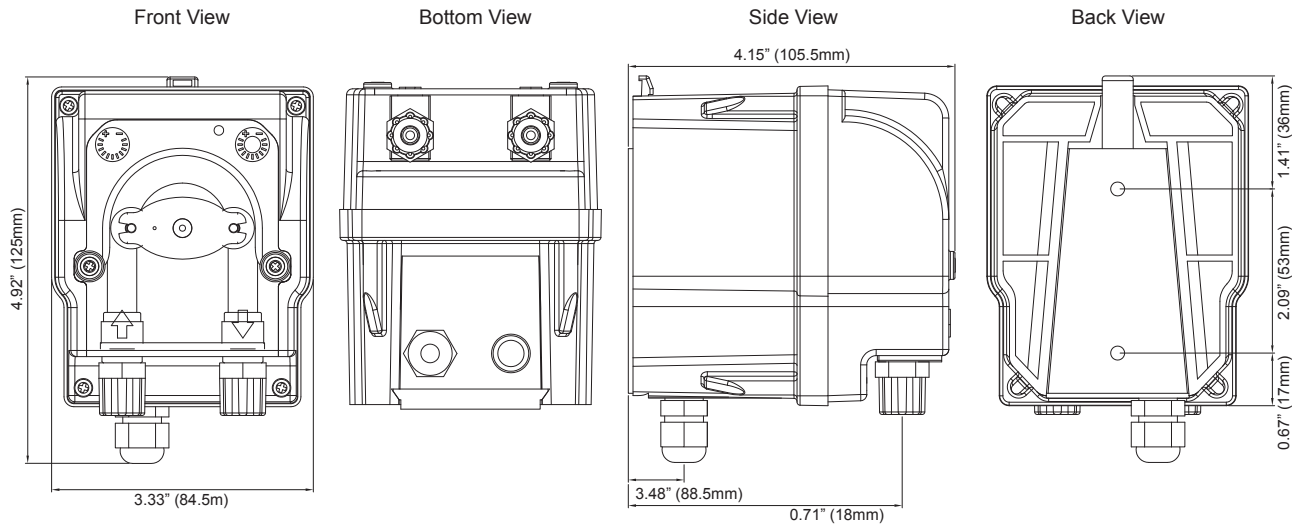

Get the Advantage



4700 Harold Abitz Dr
 Muskogee, OK 74403
 800-743-7431 phone
 888-686-6212 fax
www.advantagecontrols.com