

NanoTron

Dual Timer

Installation
Maintenance
Repair
Manual

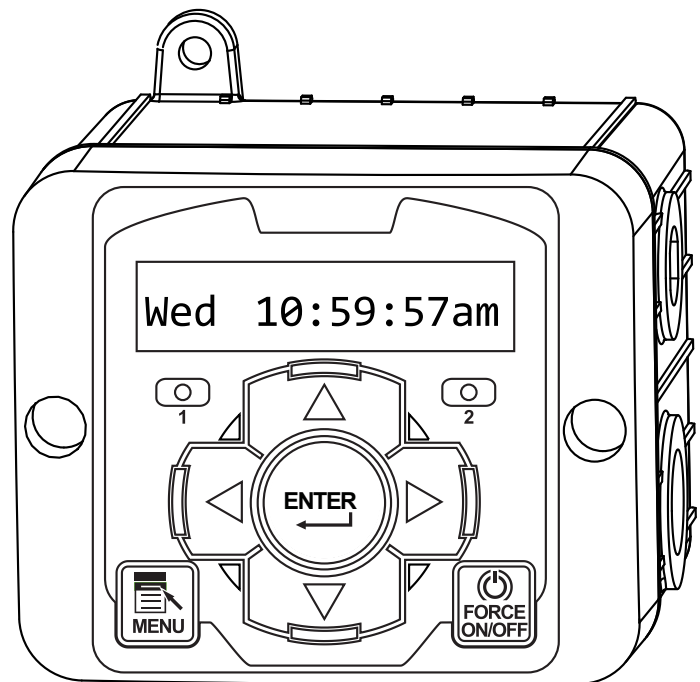

Advantage Controls
P.O. Box 1472
Muskogee, OK 74402
Phone: 800-743-7431
Fax: 888-686-6212
www.advantagecontrols.com
email: support@advantagecontrols.com

12/2015

Table of Contents

Contents	Page
I. Introduction.....	2
II. Description.....	3
NanoTron-F2 Features	3
III. Installation	
Electrical Wiring.....	3
Logic and Relay Cards	4
Mounting Instructions	4
IV. Front Panel Description.....	8
V. System Operation Overview.....	8
Description of Menus.....	8
VI. NanoTron-F2 Menu Map	9
VII. Warranty & 30 Day Billing Memo Policy	10

I. Introduction

NanoTron microprocessor based controllers are designed to provide a wide range of control functions for recirculating water treatment systems. The controller is programmed through a front panel keypad and can be configured to provide a customized control system for your application. Your particular unit's functions can be determined by comparing the units model number to the model numbering table listed below.

Model Numbering

NanoTron units have several base system control functions and unit optional features. Your unit may be supplied with one or more of the features described in this manual. To determine what features apply to your unit check the model number label located on the controller enclosure.

Base Control Function

F2 - Two Feed Timers

Whole Unit Optional Features

A - Conduit Connections

A3 - Conduit with CE

E - Flow Switch

Y - ETL Listing / Approvals

II. Description

NanoTron units are designed to automate the addition of various chemicals or activate other devices via a relay output.

Nano-F2 units include:

- * Two totalizing water meter inputs that can be configured for contacting head or hall effect meter inputs.
- * Two drum level inputs that can be set to disable the relay outputs.
- * Two mechanical relay outputs with normally open and normally closed contacts that can be configured for powered or dry contact relay operation (see page 4).
- * A “force on” timer that allows for manual activation of the relays for a user defined amount of time.

Each of the 2 timers in a NanoTron-F2 can be individually programmed as one of the following types:

1. **Pulse Timer** – Accepts dry contact pulses from a water meter (supplied separately). It can accumulate 1-9999 pulses to activate the timer to run from 0-99 minutes, 59 seconds in minutes and seconds. Timer will store up to 5 additional activations during an individual run time.
2. **Recycle Timer** – Provides a user defined “off” cycle in HH:MM and a user defined “on” cycle in MM:SS that is repeated constantly.
3. **28-Day Timer** - 28-day feed timers, typically used for biocide feed are based on a 28-day cycle with two independent programmable feed cycles allowing for feed on selectable days and weeks.
4. **Batch Timer** - Timer activated by the Force On/Off key for a user defined run time.

III. Installation

Electrical Wiring

The controller has an internal regulated power supply that will operate in the range of approximately 100 to 240 VAC on the incoming wiring. Output relay(s) are protected with a replaceable fuse. Relay output voltage will equal the incoming line voltage.

Prewired units are supplied with a 16 AWG cable with a 3-wire grounded USA 120 volt plug for incoming power and 18 AWG 3-wire grounded receptacle cords for all control relay outputs. Conduit units are supplied with liquid tight fittings and adaptors for easy hard wiring to supplied connector.

NOTE: Liquid tight fittings and some labeled signal leads are provided for signal (low voltage) connections, such as water meter inputs.

WARNINGS

1. The controller should be connected to its own isolated circuit breaker, and for best results, the ground should be a true earth ground, not shared. Wiring must be done according to all applicable local codes.
2. Power (line voltage) must be disconnected while making any connections. If power is supplied to the unit, line voltage will be present on the relay cards.
3. Low voltage signal wires (probes, flow switch, water meter, etc.) should never be run in conduit with high voltage wires.
4. Hall effect meters that require +12 VDC must use an external power supply (TFS-PWR).

Logic and Relay Cards

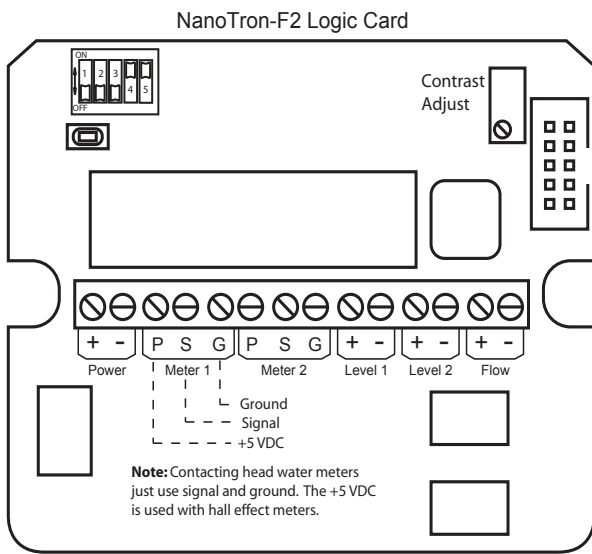
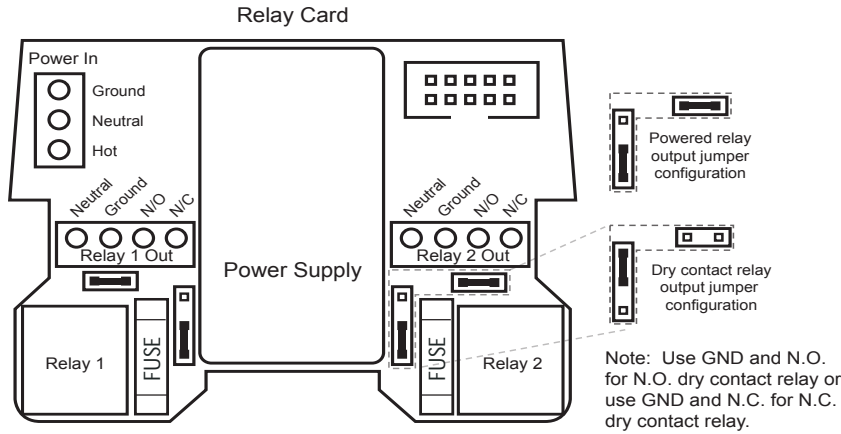

Switch #	Position	Function
1	OFF	Backlight normally off; flashes on w/ alarm
1	ON	Backlight normally on; flashes off w/ alarm
2	OFF	Normal Operation
2	ON	"Burn-in" Mode
3	OFF	Normal Operation
3	ON	Clear Memory (Resets to factory defaults)
4	OFF	N/A
4	ON	N/A
5	OFF	Set for 1x6 LCD (Normal)
5	ON	Set for 4x20 LCD (Debug @ Factory)

Mounting Instructions

Select a mounting location that provides the operator easy access to the unit and a clear view of the controls through the cover of the controller. The location should be convenient to grounded electrical connections, the needed sample line plumbing and is on a stable vertical surface.

WARNING: Avoid locations that expose the controller to direct sunlight, vapors, vibration, liquid spills or extreme temperatures; less than 0°F (-17.8°C) or greater than 120°F (50°C). EMI (electromagnetic interference) from radio transmissions and electric motors can also cause damage or interference and should be avoided.

Electrode Installation

Controllers may come configured for various circulating water systems. Listed below are instructions for cooling tower and boiler typical installations. Your specific installation requirements may differ but should conform to these instructions as much as possible for proper operation.

A. Cooling Tower

The standard probe(s) and/or flow assembly for cooling tower installations is constructed of schedule 80 PVC and supplied with 3/4" slip fittings for installing into a sample line. To insure proper operation the sample line must have a flow rate of 3-10 gpm. Inlet pressure must be higher than outlet pressure in order for water to flow past the electrode(s) to achieve the required rate. The probes are temperature compensated for increased accuracy.

NOTES:

1. Install an isolation valve on either side of the flow assembly so electrodes can be easily isolated for removal and cleaning.
2. A line strainer is recommended upstream from the probes to protect against fouling and damage.
3. Systems with a flow switch require 2-3 gpm flow rate to operate outputs.

WARNINGS:

1. Electrodes are O-ring sealed, which if damaged will cause a leak.
2. Do not allow pH sensor tips to dry out, damage will occur.
3. Do not exceed a water temperature range of 32°F to 140°F.
4. Do not exceed a maximum pressure of 150 psi.

Typical Cooling Tower Installation Diagram

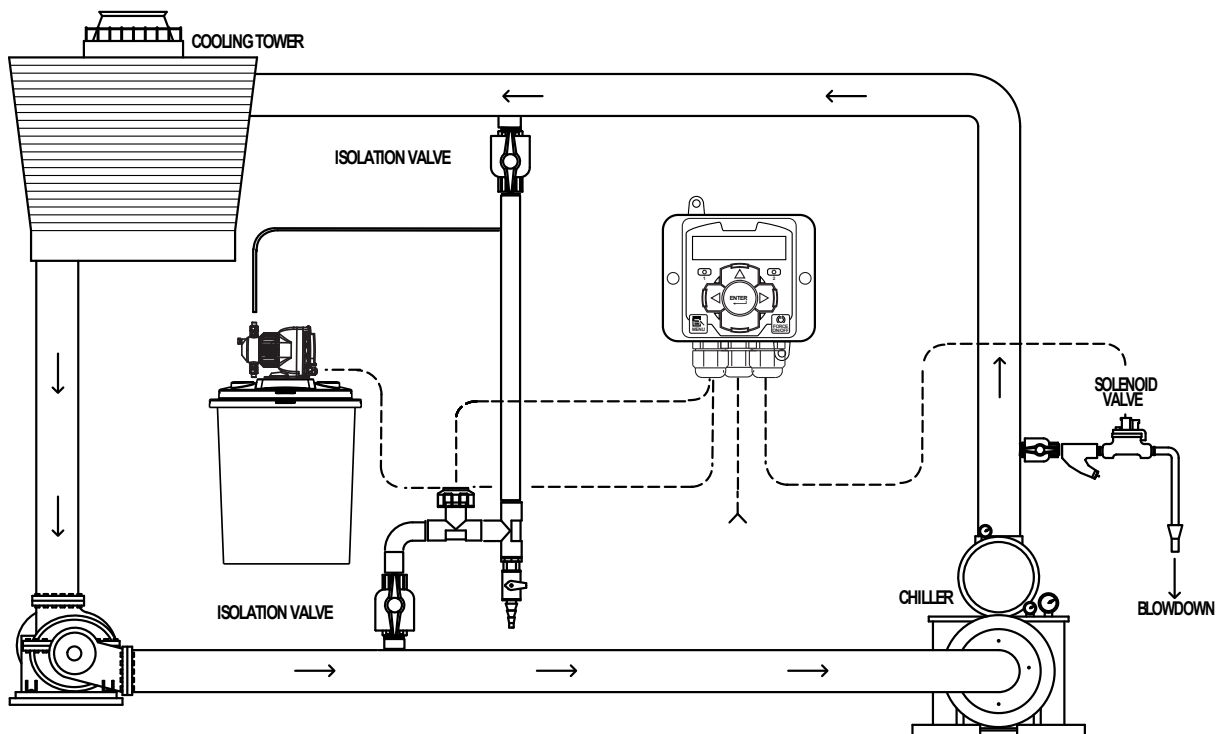

B. Boiler

Standard boiler electrodes have a MNPT stainless steel bushing and are supplied with a FNPT cross designed for mounting in the skimmer (surface) blowdown line. Sampling of the boiler's water can be achieved using one of two typical plumbing configurations (continuous sampling or timed and/or hold sampling). For a successful installation, it is critical to observe the recommended distances and pipe sizes provided in the installation drawings.

For best results, the electrode cross should be mounted in a 1" skimmer blowdown line within 4' of the boiler. Smaller line sizes and greater distances may affect the response time and accuracy of the electrode. A flow-throttling device down stream from the probe (within 12-24 inches) is required to ensure that the electrode is exposed to water and not steam. Properly installed and adjusted, this device will prevent flashing in the electrode chamber.

NOTES:

1. **Install a fully ported type valve between the electrode and the boiler. This allows the electrode to be isolated for removal and cleaning.**
2. **A flushing line and 1/4 turn type ball valve should be installed in the bottom of the cross to periodically "flush" sediment from the electrode chamber.**
3. **Make sure the alignment arrows on the probe end up parallel to the flow for best performance.**



WARNINGS:

1. **The probe must be fully immersed in the system water to read correctly. Steam flashing will result in incorrect readings.**
2. **Do not exceed a maximum water temperature of 436°F (224°C)**
3. **Do not exceed a maximum pressure of 350 psi (24.1 bar)**
4. **A throttling device must be installed down stream from the electrode.**

Boiler Conductivity Electrodes

BE-32

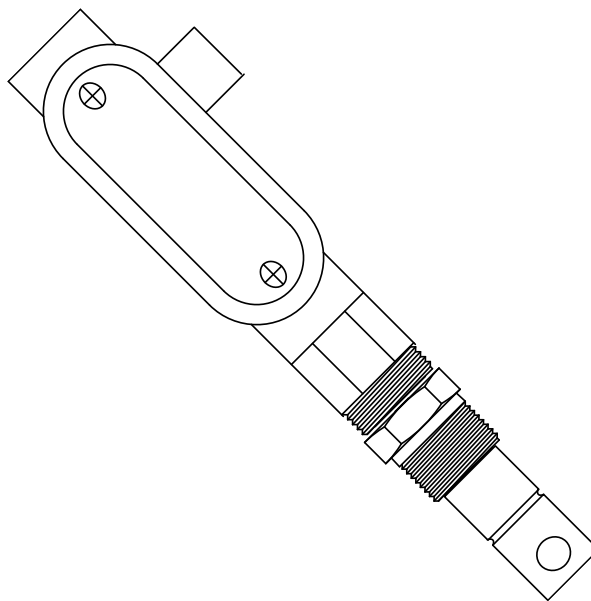

Wiring Note: BE-32 probes require a 2 conductor cable from controller to probe.

Typical Continuous Sampling Boiler Installation Diagrams

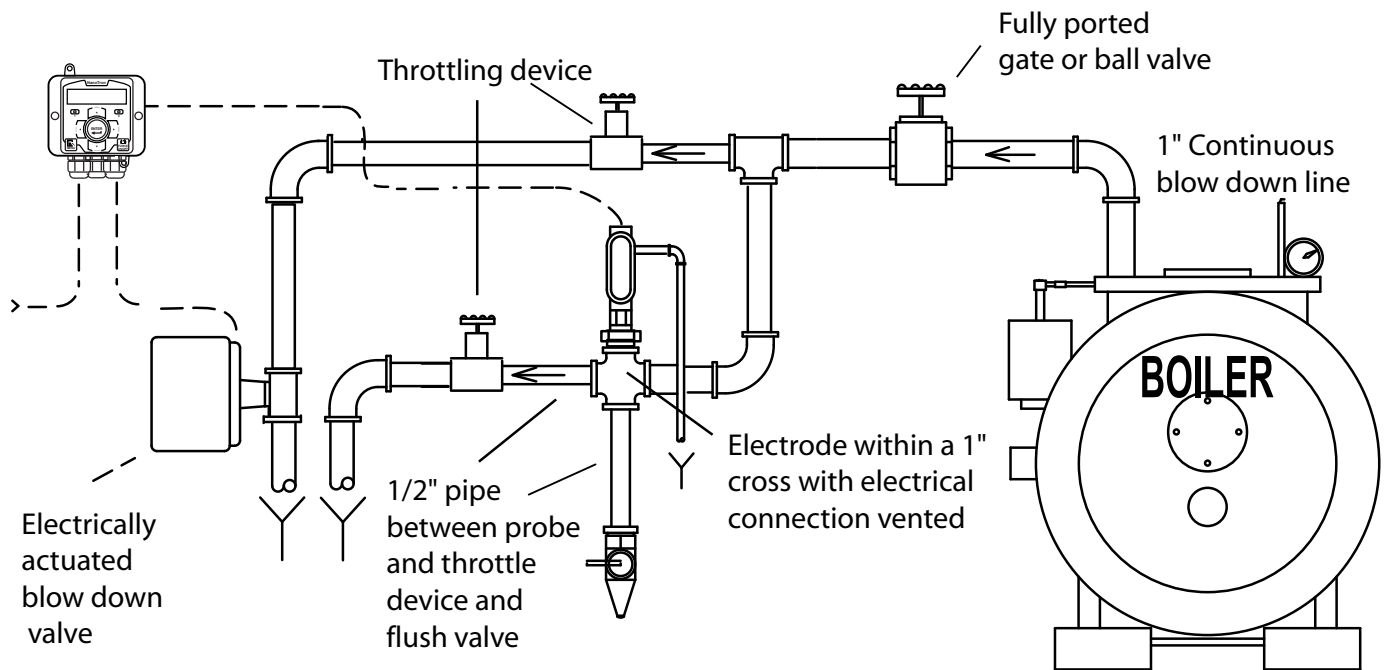

Warning - Do not use on bottom blowdown lines, only continuous or surface blowdown lines.

Typical Timed Sampling and Sample and Hold Boiler Installation

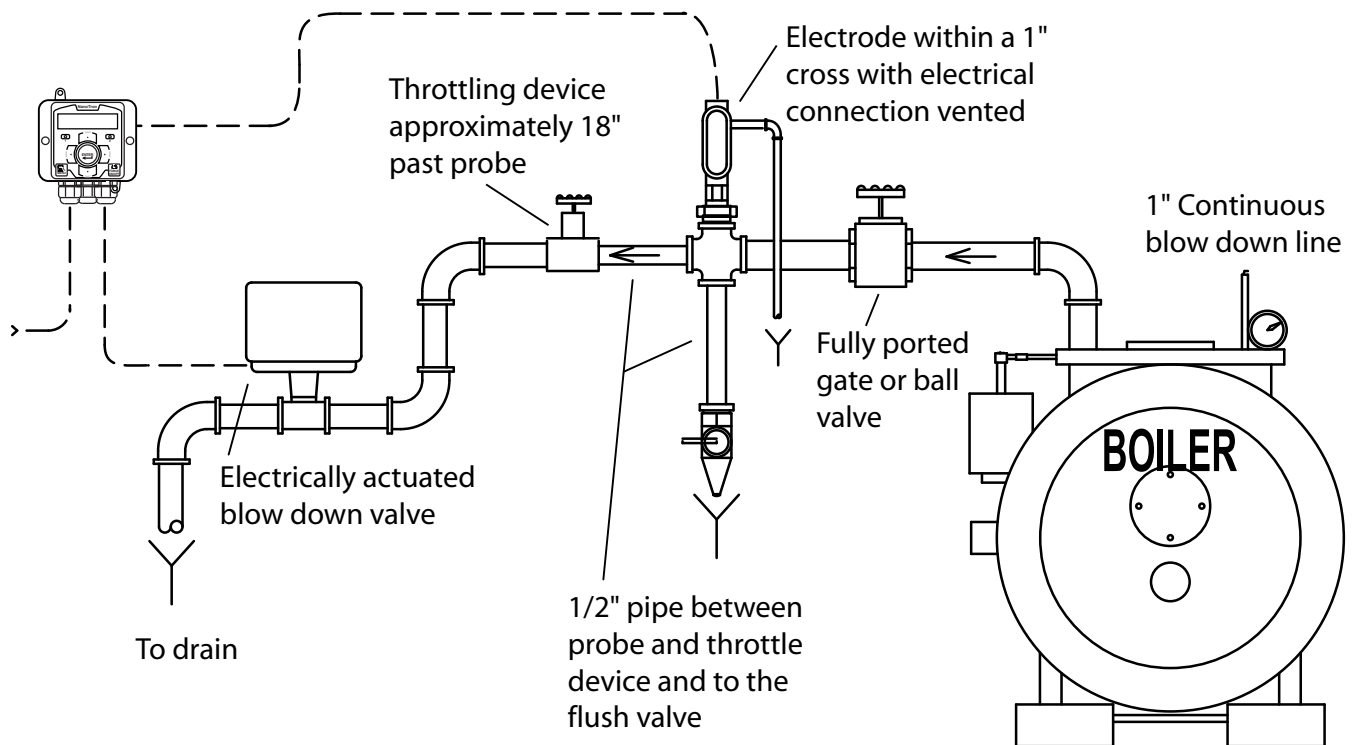

Warning - Do not use on bottom blowdown lines, only continuous or surface blowdown lines.

IV. Front Panel Description

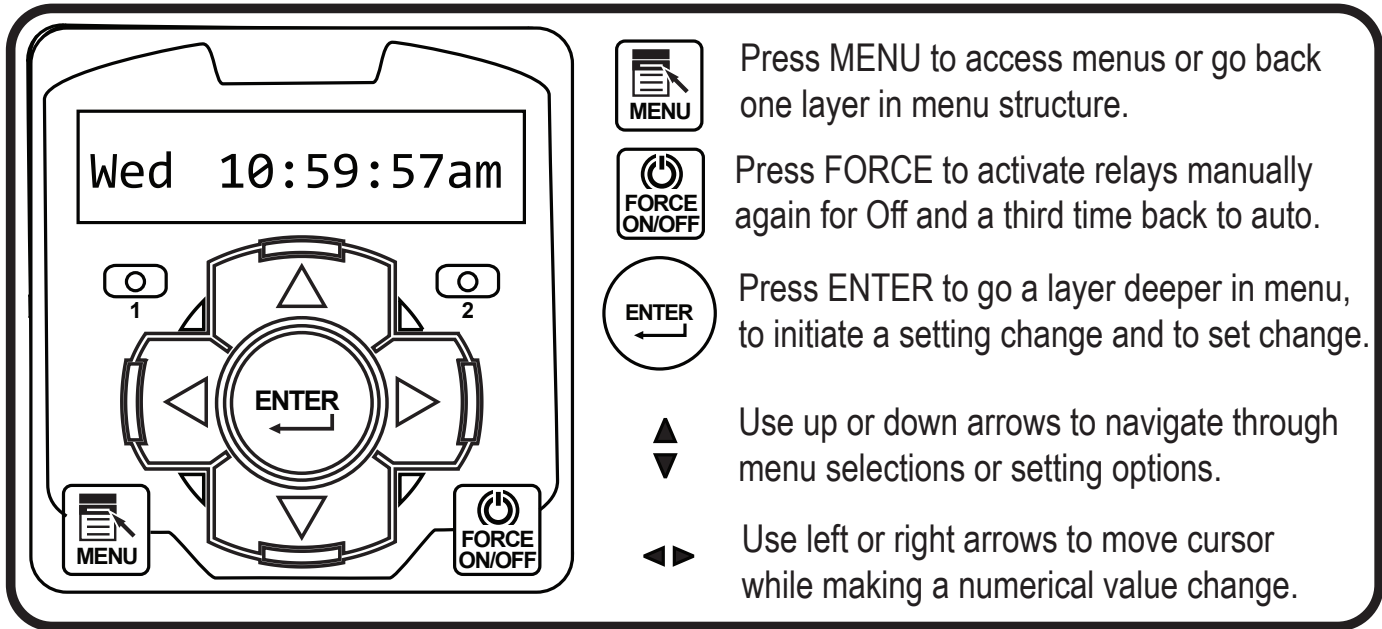

V. System Operation Overview

Description of Menus

NanoTron controllers have three modes of operation, Run, Menu and Force. All menus are circular. Pressing the DOWN key will display the next line of information on the display.

Run - This mode is for normal operation. The control relays will only be automatically active in this mode. In the Run mode, the display will read system values. If an alarm is present, the display flashes with the alarm status.

The Run menu will display values such as day, time, date and other values depending upon the features present on the unit. The unit will automatically return to the Run mode if no keys are pressed for three minutes.

Menu - This mode is used to make adjustments to settings and readings on the controller. To access the Menu mode from the run screen, press the Menu key. Use the up or down arrow to scroll through the various menus. When you want to access a specific menu, press the Enter key. Once you have entered a sub-menu you will be able to step through that menu's options with the up or down arrow key.

Force - Relays may be forced on or off for a user defined amount of time. Press the Force key to force relays on for the time configured in the Menu's force sub-menu. Press it a second time to force them off for the same amount of time. Press a third time to go back to automatic Run mode. Unit returns to the Run mode automatically when the force time has elapsed.

VI. NanoTron-F2 Menu Map

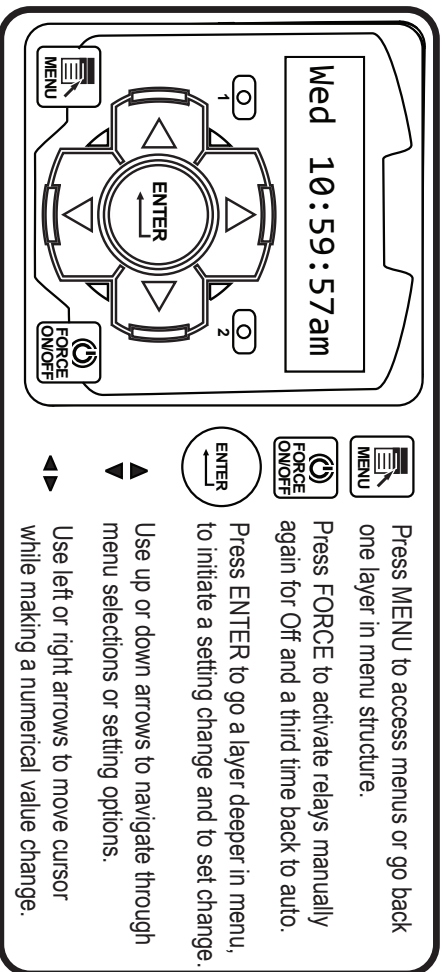
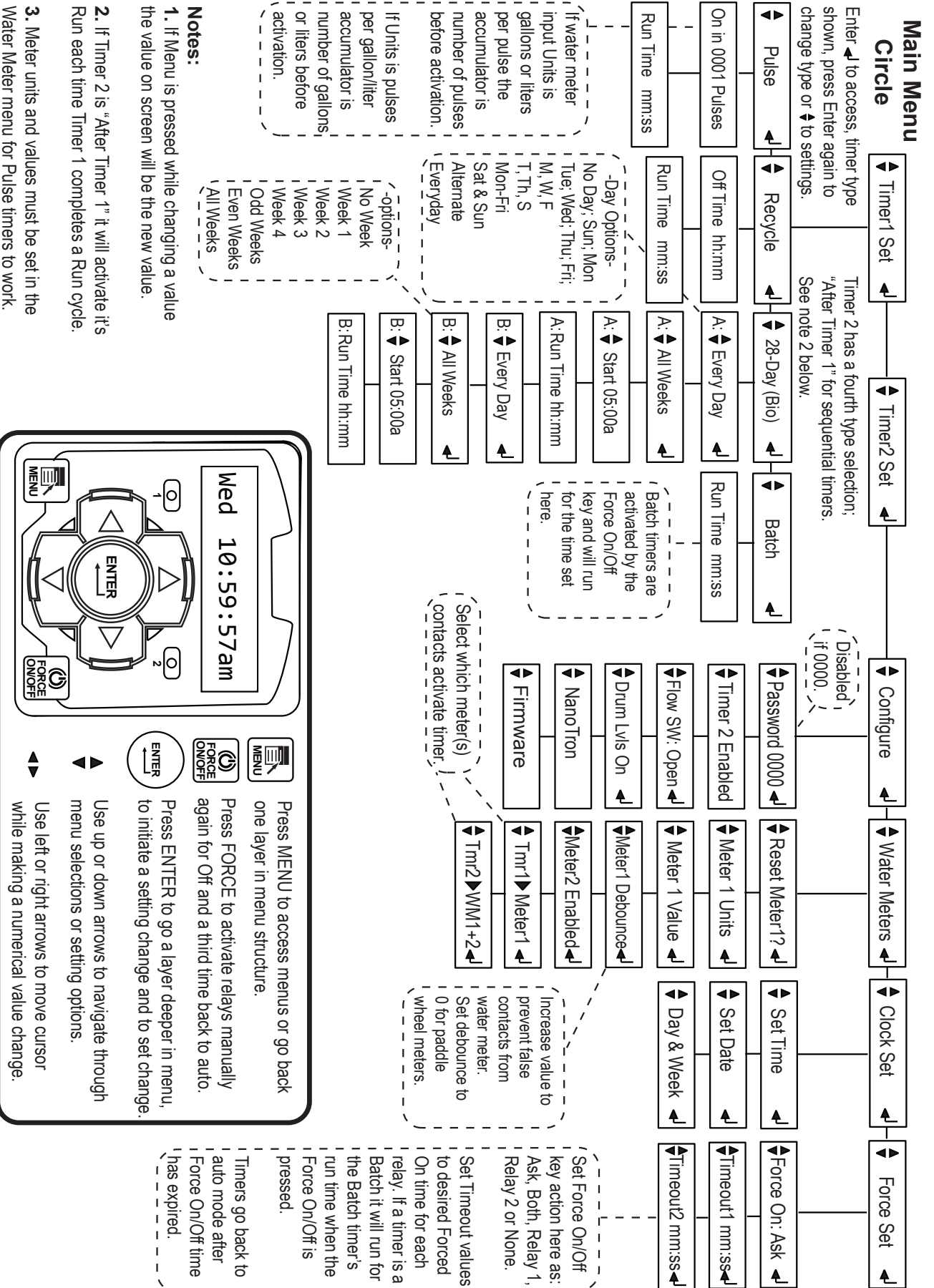

VII. Manufacturer's Product Warranty

Advantage Controls warrants units of its manufacture to be free of defects in material or workmanship. Liability under this policy extends for 24 months from date of installation. Liability is limited to repair or replacement of any failed equipment or part proven defective in material or workmanship upon manufacturer's examination. Removal and installation costs are not included under this warranty. Manufacturer's liability shall never exceed the selling price of equipment or part in question.

Advantage disclaims all liability for damage caused by its products by improper installation, maintenance, use or attempts to operate products beyond their intended functionality, intentionally or otherwise, or any unauthorized repair. Advantage is not responsible for damages, injuries or expense incurred through the use of its products.

The above warranty is in lieu of other warranties, either expressed or implied. No agent of ours is authorized to provide any warranty other than the above.

30 Day Billing Memo Policy

Advantage Controls maintains a unique factory exchange program to ensure uninterrupted service with minimum downtime. If your unit malfunctions, call 1-800-743-7431, and provide our technician with Model and Serial Number information. If we are unable to diagnose and solve your problem over the phone, a fully warranted replacement unit will be shipped, usually within 48 hours, on a 30 Day Billing Memo.

This service requires a purchase order and the replacement unit is billed to your regular account for payment.

The replacement unit will be billed at current list price for that model less any applicable resale discount. Upon return of your old unit, credit will be issued to your account if the unit is in warranty. If the unit is out of warranty or the damage not covered, a partial credit will be applied based upon a prorated replacement price schedule dependent on the age of the unit. Any exchange covers only the controller or pump. Electrodes, liquid end components and other external accessories are not included.

FCC Warning

This equipment generates and uses radio frequency energy and if not installed and used properly, that is, in strict accordance with the manufacturer's instruction, may cause interference to radio communications. It has been type tested and found to comply with the limits for a class A computing device pursuant to subpart J of part 15 of FCC Rules, which are designed to provide reasonable protection against such interference when operated in a commercial or industrial environment. Operation of this equipment in a residential area is likely to cause interference in which case the user, at his own expense, will be required to take whatever measures necessary to correct the interference.

Get the Advantage in Water Treatment Equipment

Advantage Controls can give you the *Advantage* in products, knowledge and support on all of your water treatment equipment needs.

- Cooling Tower Controllers
- Boiler Blow Down Controllers
- Blow Down Valve Packages
- Solenoid Valves
- Water Meters
- Chemical Metering Pumps
- Corrosion Coupon Racks
- Chemical Solution Tanks
- Solid Feed Systems
- Feed Timers
- Filter Equipment
- Glycol Feed Systems
- Pre Fabricated Systems

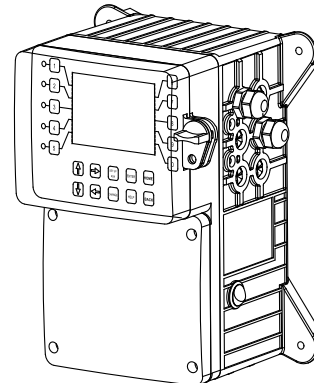
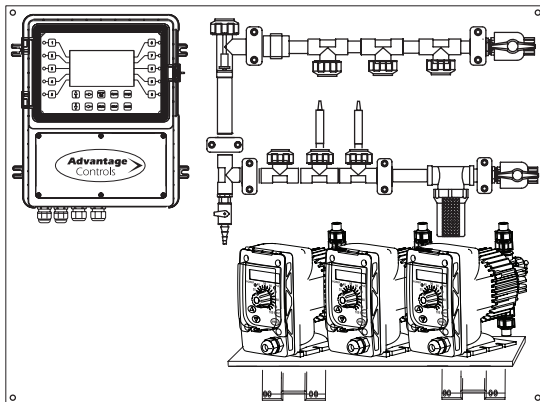
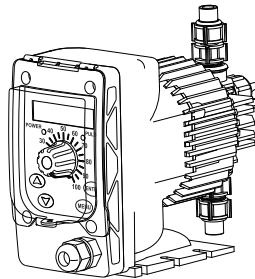
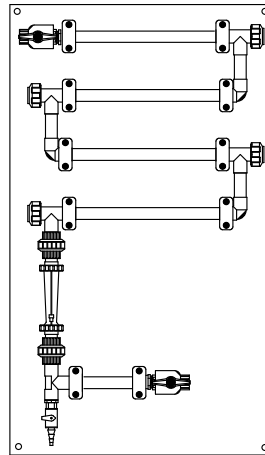
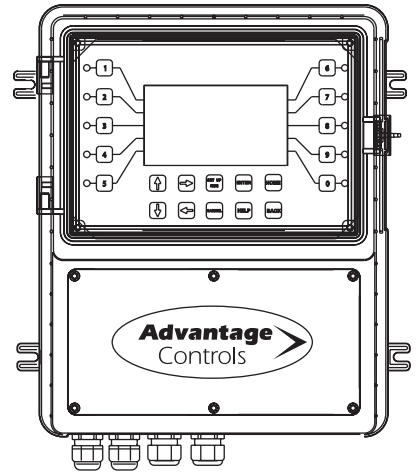
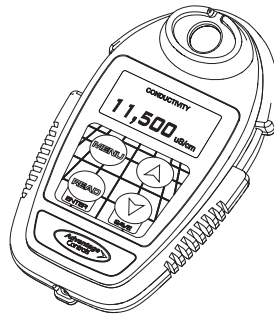

Get the Advantage

